



CROWN™

INSTALLATION INSTRUCTIONS







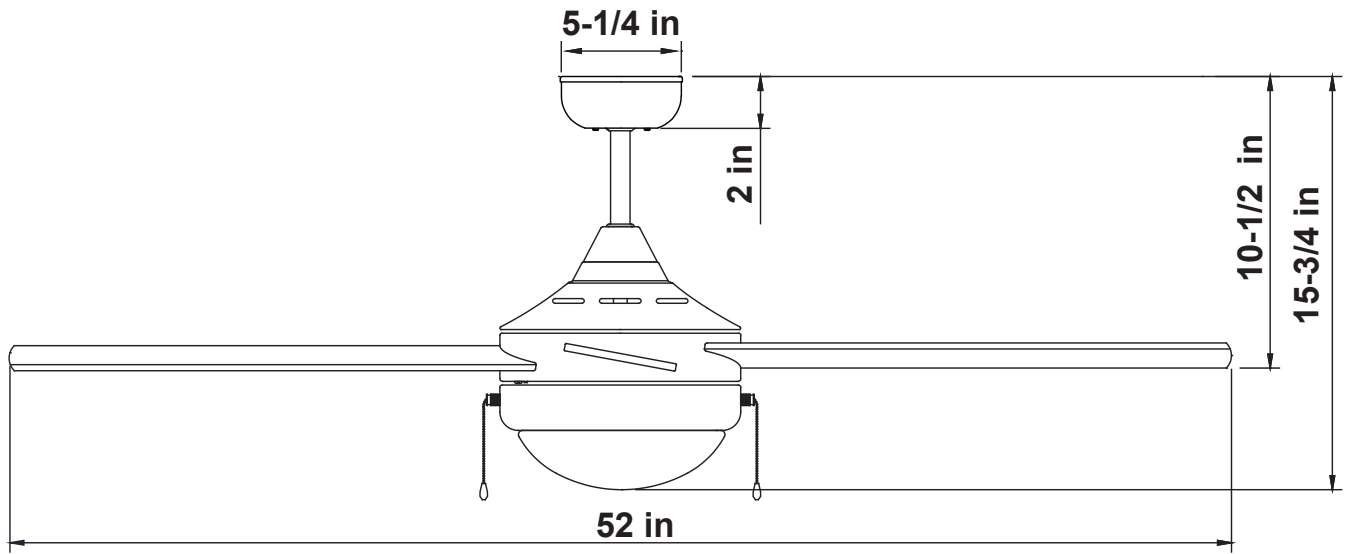

52-INCH INDOOR LED CEILING FAN / 4 Blades / Pull Chain





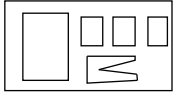



Dimension Reference:

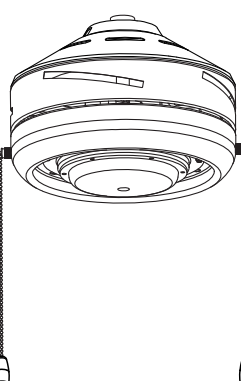

Hardware Package Included:

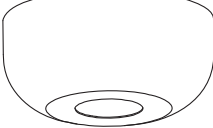
Hardware Package		Quantity
 S1	 S9	
 S2		
 S3		
 S4	 S10	
 S5		
 S6		
 S7		
 S8		
S1. Blade Screws & Washers		13
S2. Machine Screws		2
S3. Machine Screws		2
S4. Wood Screws		2
S5. Washers		2
S6. Lock Washers		2
S7. Star Washers		2
S8. Wire Nuts		3
S9. Paper Washers		13
S10. Balance Kit		1

Fan Parts Included:

Fan Parts Included:		Quantity	
 ← 1	 ← 5	1. Mounting Bracket	1
 ← 2		2. Support Rod & Cotter Pin	1
 ← 3		3. Canopy	1
 ← 4		4. Coupler Cover	1
 ← 6		5. Fan Motor Assembly	1
		6. Glass	1
		7. Fan Blade	4
	 ← 7		

Exploded View:

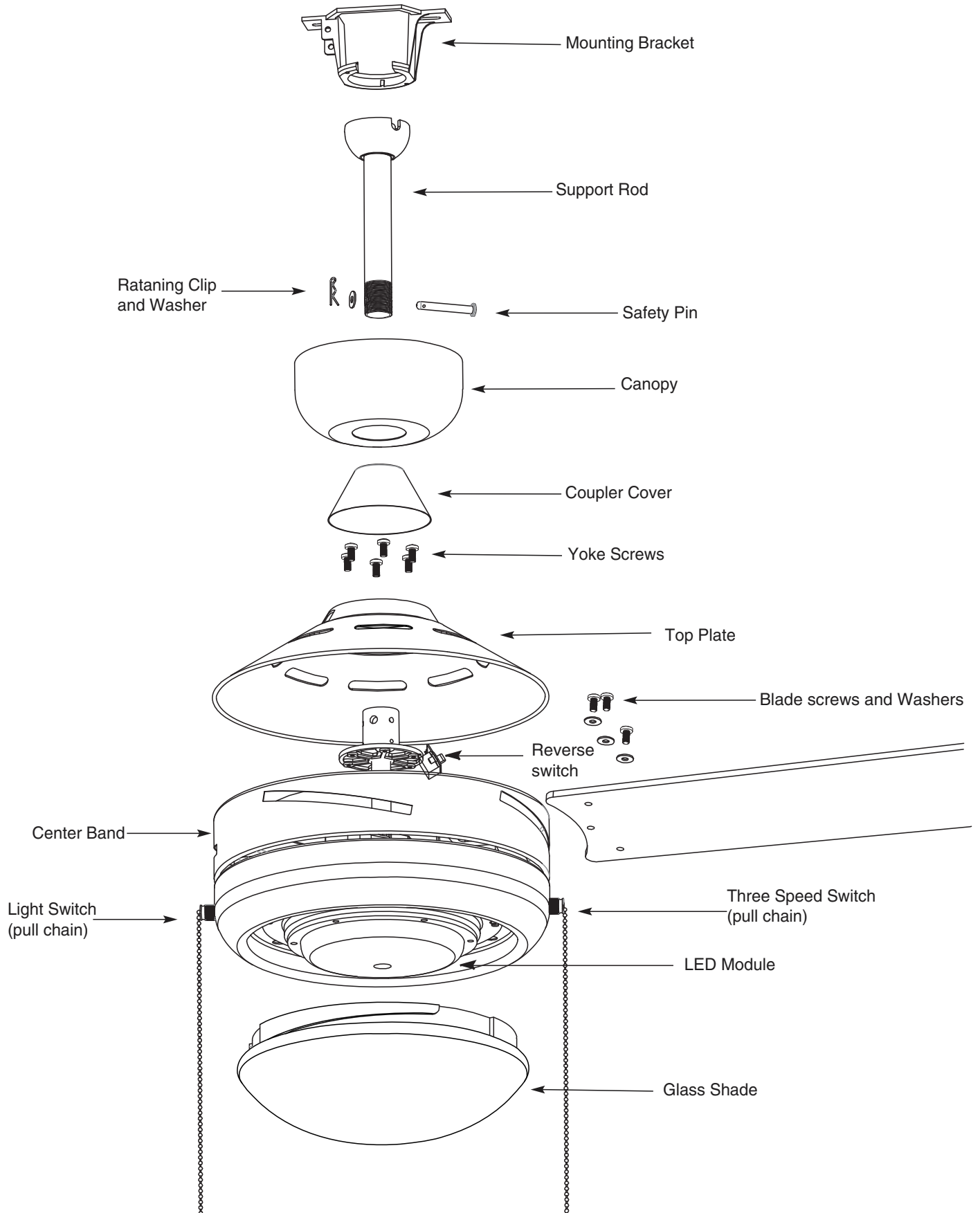

Safety Instructions:

READ ALL SAFETY INFORMATION AND INSTALLATION INSTRUCTIONS BEFORE YOU BEGIN INSTALLING THE FAN. IF YOU ARE NOT FAMILIAR WITH NATIONAL AND LOCAL ELECTRICAL CODES AND BASIC ELECTRICAL WIRING PROCEDURES WE RECOMMEND THAT YOU HAVE A QUALIFIED ELECTRICIAN INSTALL YOUR NEW CEILING FAN. SAVE INSTRUCTIONS.

- Avoid the risk of electrical shock be sure to shut off power at main fuse or circuit breaker box before installing or servicing fixture.
- Make sure that all wiring conforms to national and local electrical codes. If you are in question obtain a copy of codes and wire the fan accordingly. Never leave bare wire uncovered, use wire nuts to cap all connections. Plastic electrical tape not recommended.
- Basic requirements for a ceiling fan installed with lights are 120V AC-60Hz on a grounded circuit with a 15 amp breaker or fuse. Make sure that your electrical system and choice of location meet these requirements.
- If the location where you plan to install your fan does not already have an electrical outlet, hire a licensed electrician to run wiring and install an outlet box designed for ceiling fans or heavy fixtures. Outlet box should be able to support a minimum moving weight of 50 pounds and marked "Acceptable for Fan Support" (*Plastic outlet boxes not recommended for ceiling fan installation*).
- If you plan to use an existing electrical location check to make sure that the outlet box is not PLASTIC, that it is securely attached and able to support at least 50 pounds of moving weight marked "Acceptable for Fan Support". If you have any questions, outlet boxes and support systems for ceiling fans are available at most hardware and do-it-yourself centers. In most cases your Truly Green Solutions dealer will have all the necessary products for the proper and safe installation of your ceiling fan.
- The location you choose should have a minimum clearance of 20 inches from any wall to the blade tip at any point in its rotation and a minimum of 7 feet from blade level to floor and 10 inches from the blades to the ceiling.
- This ceiling fan was not designed for installation in any location where it might be exposed to moisture or high humidity. Installation in this type of location could be UNSAFE, will most likely damage the fan and its finish...and will VOID YOUR WARRANTY.
- Every effort has been made to provide you with proper instructions for the safe installation of this ceiling fan. You could however, encounter situations or problems not covered in this manual. Should this occur, please refer to a do-it-yourself wiring handbook or hire a qualified electrician to install your fan.
- Lubrication of your new ceiling fan is not necessary. The ball bearings have been adequately charged with grease and permanently sealed at the factory so that, under normal conditions, further attention is not necessary.
- NOTE: The safeguards provided by these safety instructions and by any separate installation instructions are not meant to cover all possible conditions and situations that may occur. It must be understood that common sense, caution and care are factors which can not be built into this product. These factors must be supplied by the person(s) installing, caring for and operating fan.

Warning:

- To reduce the risk of fire, electrical shock, or personal injury, mount this fan to an outlet box marked “Acceptable for Fan Support of 22.7 kg (50 lbs)” or less and use Mounting Screws provided with the outlet box. CAUTION: Install the primary mounting means and use only the hardware provided with the fan.
- To reduce the risk of personal injury take care not to bend the blade brackets when installing the brackets, balancing the blades or cleaning the fan. Be careful not to insert foreign objects in between rotating fan blades.
- To reduce the risk of fire or electrical shock, do not use this fan with any solid-state speed control device.
- The important safeguards and instructions appearing in this manual are not meant to cover all possible conditions and situations that may occur. It must be understood that common sense, caution and careful attention to detail are factors which cannot be built into this product. These factors must be supplied by the person or persons installing, caring for, and operating the unit.

Installation Instructions:

Step 1 Fan Assembly

Remove the screws from coupler cover and lift the coupler cover and set aside. Remove the screws from top plate located on the motor yoke. Lift top plate and set aside.

Time Saver: Washers for blade screws can be set on each blade screw prior to installing blades.

Locate 12 pcs blade attachment screws and washers in the hardware pack. Slide a blade through the center band and align holes. Insert 3 pieces blade screws and washers with fingers. Tighten securely with a phillips screwdriver. Repeat for the remaining blades.

Reattach top plate to motor yoke and install it by aligning the key slot holes on the motor yoke using previously removed screws.

Note: The reverse switch must be set in the rectangular hole labeled on the top plate.

Note: If you are using an extended support rod, (longer than the one supplied with your fan) remove the half ball from the support assembly and attach it to the extended support rod at this point. Make sure to retighten the set screw and insert the safety pin.

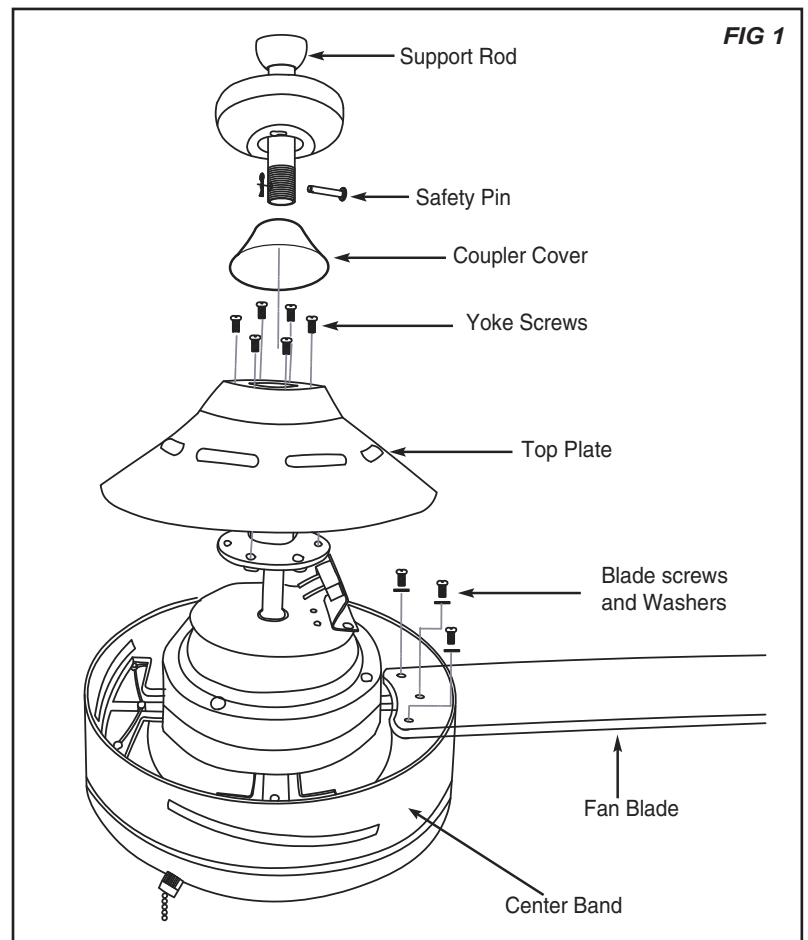

Back off (loosen) the set screws (2) in the support rod coupler until the inside of the channel is clear of the screw tip. Remove and save the safety pin and washer on the end of the support rod assembly. Slide the ceiling canopy onto the support rod, followed by the support rod coupler cover (see **figure 1**). Feed the electrical wires from the fan housing through the support rod.

Thread the support rod into the support rod coupler until the safety pin can be inserted through the hole in both the rod and coupler. Insert the safety pin through the hole in the support rod coupler and support rod then attach washer into safety pin and the retaining clip on the other side. Tighten both set screws and safety screw on the support rod coupler.

Step 2 Install Mounting Bracket

Loosen the two canopy mounting screws on the downside face of the mounting bracket. Back them out about half way. This will allow for easier installation of the ceiling canopy later (see **figure 2**).

Install the mounting bracket onto the electrical junction box in the ceiling using two machine screws, two washers and two lock washers (see **figure 3**).

The mounting bracket has slotted holes to enable it to move sideways for proper alignment. Make sure the mounting bracket is centered over the electrical junction box and that it is securely attached (see **figure 4**).

NO MOVEMENT SHOULD OCCUR BETWEEN THE MOUNTING BRACKET AND THE ELECTRICAL JUNCTION BOX.

Pull the electrical wires in the junction box down and through the mounting bracket.

Step 3 Hanging the Fan Body

Notice the half ball on the end of the support rod is grooved down one side (see **figure 5**). This Keyway fits over the small keyway pin on the inside of the mounting bracket and keeps the ceiling fan from spinning on the mounting bracket.

Using your step ladder, lift the fan and place the half ball in the center of the mounting bracket with the keyway pin inserted into the keyway on the ball. Turn the fan left and right slightly to make sure it is seated on the bracket with the keyway pin in the keyway (see **figure 6**).

Trim the lead wires, leaving about six inches of each wire extending from the support rod (see **figure 7**).

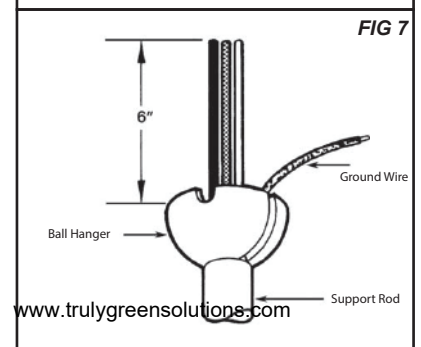
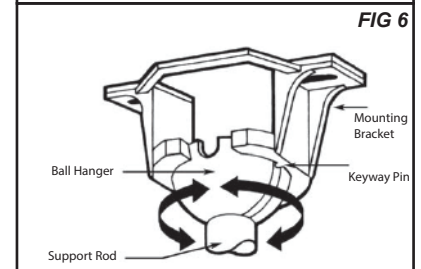
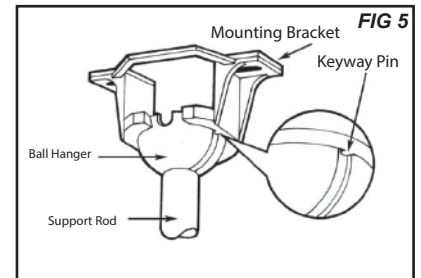
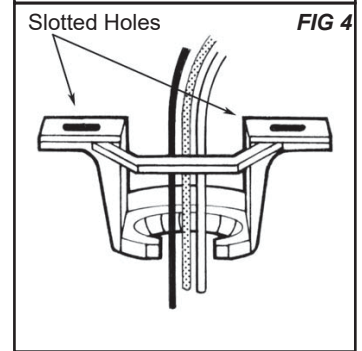
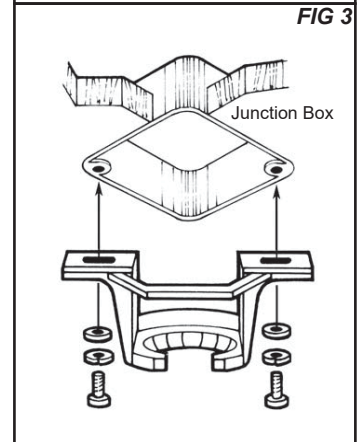
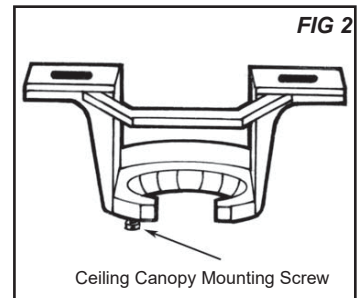

Step 4 Making the Electrical Connections

To operate your ceiling fan with the pull chain(s) and switches mounted on your fan, follow the instruction below (see **figure 8-1**).

Attach the GREEN wire (connected to the half ball) to the GROUND wire in the junction box. The GROUND wire is usually a bare copper wire without plastic insulation. It could also be covered in green plastic insulation.

Attach the BLACK wire and BLUE wire from the ceiling fan to the BLACK wire in the junction box.

Attach the WHITE wire from the ceiling fan to the WHITE wire in the junction box.

Fold the connected wires (see **figure 8-2**) and push them up inside the electrical junction box with the BLACK and BLUE wires to one side and the WHITE and GREEN to the other side. Make sure the wire nuts do not come loose during this operation.

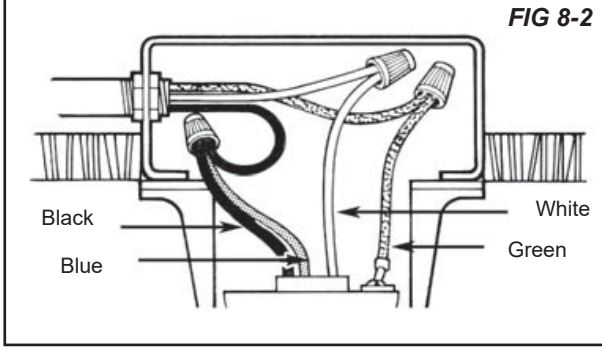
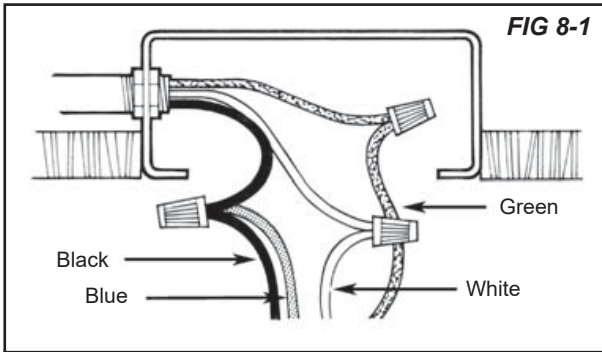

Step 5 Installing Ceiling Canopy onto Mounting Bracket

Secure the ceiling canopy onto the mounting bracket using canopy mounting screws (see **figure 9**).

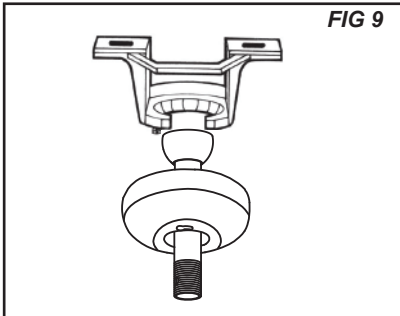

Step 6 Installing Glass Shade

The LED module is pre-installed on the mounting plate. Place glass cover on bottom motor plate and rotate until secure (see **figure 10**).

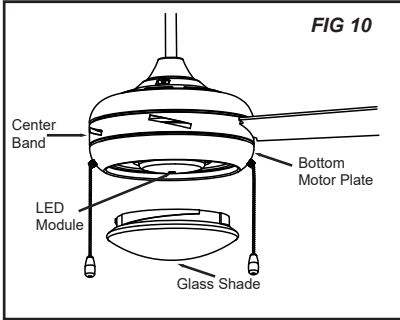

Operation:

The pull chain located on the switch housing controls the speed of your fan. When the fan is OFF, pull the chain once for HIGH speed, twice for MEDIUM speed, three times for LOW speed and a fourth time to turn it off again.

Turn fan completely off before moving the reverse switch. Set reverse switch to recirculate air depending on the season: LEFT position in summer (1), RIGHT position in winter (2). IMPORTANT: If the reverse switch is set in the (3) middle position the fan will not operate. Attach the pull chain extensions supplied or custom pull chains (sold separately) to ends of the pull chains.

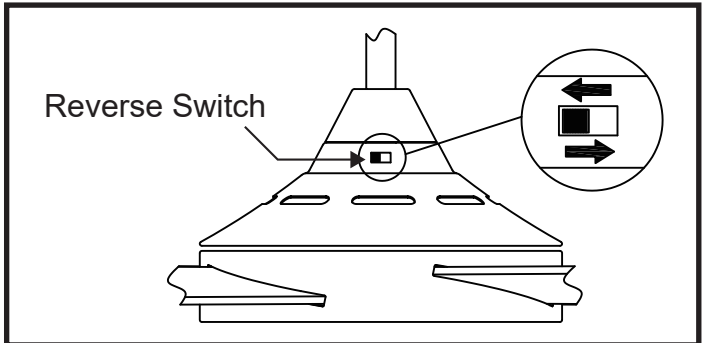
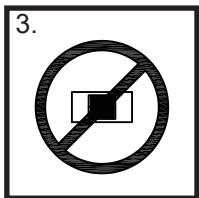
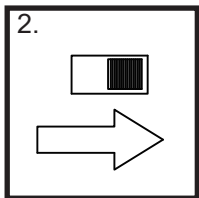
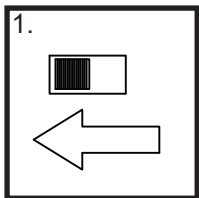

Maintenance:

Your fan requires very little maintenance. Cleaning of the housing should be done with a damp soft cloth (NO CLEANING AGENTS). On the blades, use a duster or dry cloth because any moisture could cause the blades to warp.

Conforms To D.O.E. EPACK Regulation

Troubleshooting Guide:

If you have difficulty operating your new ceiling fan it may be the result of incorrect assembly, installation, or wiring. In some cases these installation errors may be mistaken for defects. If you experience any faults please check this troubleshooting guide.

Problem	Suggested Remedy:
1. If fan does not start:	<ol style="list-style-type: none">1. Check main and branch circuit fuses or circuit breakers.2. Check line wire connections to fan and switch wire connections in switch housing. CAUTION: Make sure main power is turned off.3. Make sure forward/reverse switch is firmly in up or down position. Fan will not operate when switch is in the middle.4. Make sure that the wall controller is turned "ON".
2. If fan sounds noisy:	<ol style="list-style-type: none">1. Make sure all screws in motor housing are snug (not over tightened).2. Make sure the screws which attach the fan blade holder to the motor are tight.3. Make sure wire nut connectors in switch housing are not rattling against each other or against the interior wall of the switch housing. CAUTION: Make sure main power is turned off before entering switch housing.4. If using an optional ceiling fan light kit check to be sure the screws securing the glass shade are tight. Check to be sure the light bulb is tight on the socket and not touching the glass shade.5. Some fan motors are sensitive to signals from solid state variable speed controls. DO NOT USE a solid state variable speed control.6. Your ceiling fan's "break in" period is 24 hours of operation. Most noises associated with a new fan will disappear after this period.
3. If fan wobbles:	<p>All blades are weighed and grouped by weight. Natural woods vary in density which could cause the fan to wobble even though all blades are weight-matched. The following procedures should eliminate most of the wobble. Check for wobble after each step.</p> <ol style="list-style-type: none">1. Check that all blades are screwed firmly into blade holders.2. Check that all blade holders are tightened securely to motor.3. Make sure that canopy and mounting bracket are tightened securely to ceiling junction box and junction box is mounted firmly to ceiling joist.4. Most fan wobble problems are caused when blade levels are unequal. Check this level by selecting a point on the ceiling above the tip of one of the blades keeping measure within 1/8 in. Rotate the fan until the next blade is positioned for measurement. Repeat for each blade. If all blade levels are not equal you can adjust blade levels by the following procedure. To adjust a blade tip down insert a washer (not supplied) between the blade and blade holder at the screw closest to the motor. To adjust a blade tip up insert washer (not supplied) between the blade and blade holder at the two screws farthest from the motor.5. If blade wobble is still noticeable interchanging two adjacent (side by side) blades can redistribute the weight and possibly result in smoother operation.
4. If light does not work:	<ol style="list-style-type: none">1. Check blue wire from fan to make sure it is connected to hot wire from the house.2. Check for loose or disconnected wires in fan switch housing.3. Check for loose or disconnected wires in light kit.4. Check for faulty light bulbs. CAUTION: Make sure main power is turned off before entering switch housing.5. If the fan light shuts off shortly after being switched on it may be due to excessive current demand. Turn off power to the fan and replace the light bulbs with lower wattage bulbs. Turn on power to the fan using the pull chain, wall switch, or remote control (whichever is installed on the particular fan).