

Date:	
Project Name:	
SKU #:	

ELEMENT™ 2
Direct/Indirect Architectural Troffer



APPLICATIONS

Commercial, Retail, Institution, and Hospitality

FEATURES

- | | |
|--|--|
| <p>Construction</p> <ul style="list-style-type: none"> - 0.5mm Die-formed Cold-Rolled Steel Body | <p>Finish</p> <ul style="list-style-type: none"> - White |
| <p>Electrical & Technical</p> <ul style="list-style-type: none"> - Input Voltage: 100-277VAC - Input Frequency: 50/60Hz - Projected L70 > 50,000 hrs - PF: >0.9 - CRI: >80 - THD: <20% - Field- Adjustable Lumen Output - CCT Selectable: 3000K/3500K/4000K/5000K - Operating Temp.: -4°F ~ 113°F - Emergency Battery Backup Driver [Option] [Factory Installed] - Damp Location Rated | <p>Optical</p> <ul style="list-style-type: none"> - 120° Beam Angle |
| <p>Controls</p> <ul style="list-style-type: none"> - 0-10V Dimming [Standard] - Lutron Vive PowPak [Option][Factory Install] | <p>Installation/Mounting</p> <ul style="list-style-type: none"> - Recessed Mount |
| <p>Lumen Output</p> <ul style="list-style-type: none"> • 1'x4': <ul style="list-style-type: none"> 24W (2,760lm) 36W (4,140lm) 42W (4,830lm) 50W (5,750lm) • 2'x4': <ul style="list-style-type: none"> 30W (3,450lm) 35W (4,025lm) 40W (4,600lm) 50W (5,750lm) • 2'x2': <ul style="list-style-type: none"> 24W (2,760lm) 35W (4,025lm) 40W (4,600lm) • 2'x4'*: <ul style="list-style-type: none"> 50W (5,750lm) 60W (6,900lm) 72W (8,280lm) | <p>Warranty</p> <ul style="list-style-type: none"> - 5 Year Warranty See warranty documentation for more information. |



ORDERING INFORMATION **EXAMPLE: ELE2-22-W-C-U-D**

Series	Size	Wattage	CCT	Input Voltage	Dimming	Emergency Driver
ELE2	14 - 1'x4'	W - 24W/36W/42W/50W	C - 3000K/3500K/4000K/5000K	U - 100-277V	D - 0-10V Dimming	(Blank) No Emergency Driver EM - 8W Emergency Driver
	22 - 2'x2'	W - 24W/35W/40W				
	24 - 2'x4'	W1 - 30W/35W/40W/50W W2 - 50W/60W/72W*				
						Accessory
						FCJSO (Lutron Vive Powpak)

DIMENSIONS

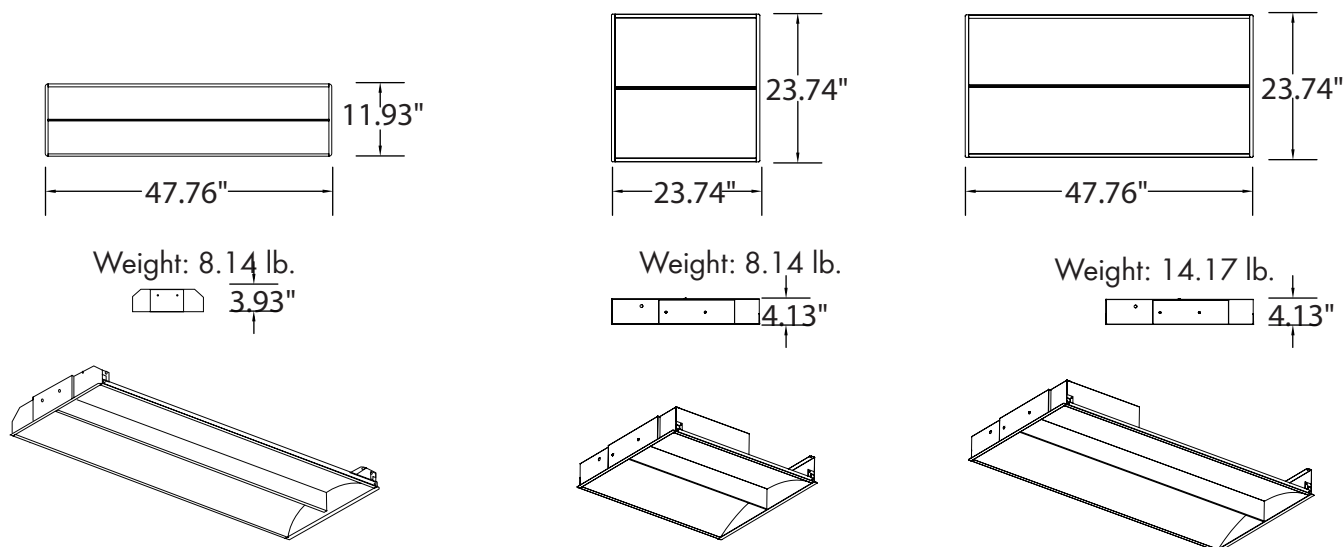

LUMEN OUTPUT

SKU	Size (LxW)	Wattage (W)	Delivered Lumens (lm)	Efficacy (lm/W)	Delivered Lumens (lm)	Efficacy (lm/W)	Delivered Lumens (lm)	Efficacy (lm/W)	Delivered Lumens (lm)	Efficacy (lm/W)
ELE2-14-W-C-U	1'x4'	24/36/42/50	2760 (24W)	115	4140 (36W)	115	4830 (42W)	115	5750 (50W)	115
ELE2-22-W-C-U	2'x2'	24/35/40	2760 (24W)	115	4025 (35W)	115	4600 (40W)	115	4600 (40W)	115
ELE2-24-W1-C-U	2'x4'	30/35/40/50	3450 (30W)	115	4025 (35W)	115	4600 (40W)	115	5750 (50W)	115
ELE2-24-W2-C-U	2'x4'	50/60/72	5750 (50W)	115	6900 (60W)	115	8280 (72W)	115	8280 (72W)	115

ACCESSORIES



8W Emergency
Battery Backup
[Factory Installed]
(Option)
[EM]



Lutron Vive
PowPak
[Factory Install]
(Option)
[FCJS0]