

Date:	
Project Name:	
SKU #:	

WPF™ S
Slim Full Cutoff Wall Pack



APPLICATIONS

Commercial, Industrial, Retail, Institutions

FEATURES

Construction

- Two-Piece Die-cast Aluminum Housing
- 3G Vibration Compliant According to ANSI C136.31.

Finish

- Dark Bronze [Powder Coated Finish]

Electrical & Technical

- Input Voltage: 120-277V
- Input Frequency: 50/60Hz
- Projected Life: L70 > 50,000 hrs
- PF: >0.9
- CRI: 70
- THD: <20%
- CCT Selectable: 3000K/4000K/5000K
- Operating Temp.: -40°F ~ 104°F
- Suitable for Wet Locations
- Integrated 8W Emergency Battery Backup [Option Not Available for 100W] [Factory Installed]

Optical

- PC Optical Lens
- Provides Type III Distribution

Installation/Mounting

- Wall Mounted With 1/2" NPT Conduit Opening
- Directly Mount onto a 4" J-Box

Controls

- 0-10V Dimming
- Photocell Option [Factory Installed]

Lumen Output

- 65W: 9,620lm
- 100W: 14,900lm

Warranty

- 5 Year Warranty
See warranty documentation for more information.



ORDERING INFORMATION

EXAMPLE: WPFS-S-L-C-U-D

Series	Size	Wattage	CCT	Input Voltage	Finish
WPFS	S - Small	L (65W/49W/34W/23W)	C - 3000K/4000K/5000K	U - 120-277V	D - Dark Bronze
	M - Medium	L (100W/84W/61W/42W)			

Accessories

- WP-PH (Photocell Factory Installed)
- WP-EM (8W Emergency Battery Backup [Not Available for 100W])

DIMENSIONS

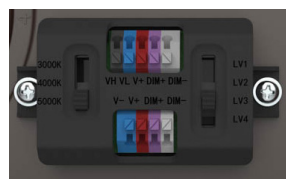
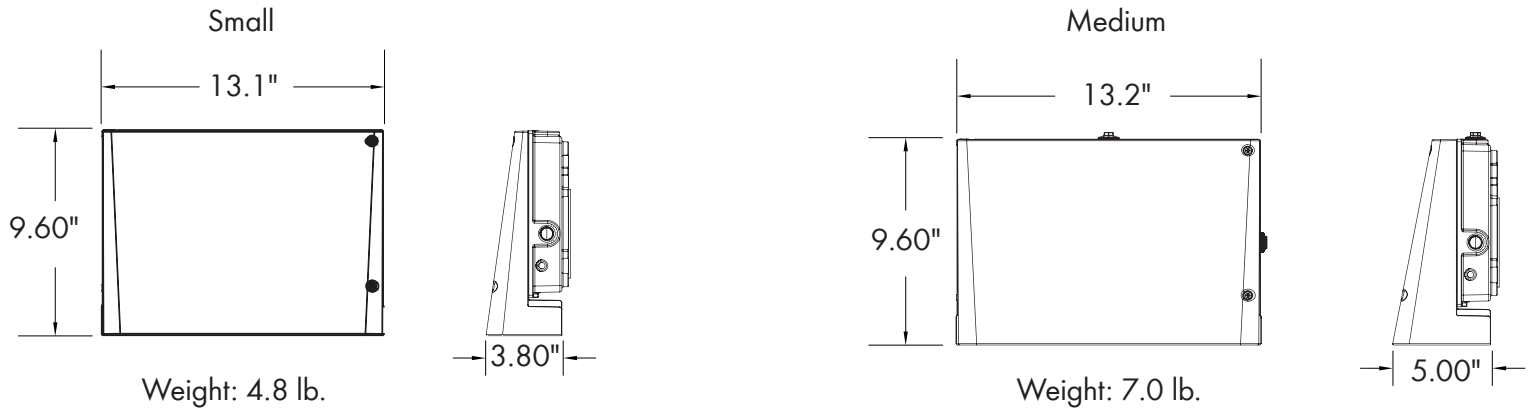

Field Adjustable Lumen & CCT Switches

LUMEN OUTPUT

SKU	Wattage (W)	Delivered Lumens (lm) 100%	Efficacy (lm/W)	Delivered Lumens (lm) 80%	Efficacy (lm/W)	Delivered Lumens (lm) 60%	Efficacy (lm/W)	Delivered Lumens (lm) 40%	Efficacy (lm/W)
WPFS-S-L-C-U-D	65/49/34/23	9620	148	7252	148	5032	148	3404	148
WPFS-M-L-C-U-D	100/84/61/42	14900	149	12516	149	9089	149	6258	149

ELECTRICAL LOAD

Wattage (W)	Current (A)						
	120V	208V	240V	277V	347V	480V	Input Voltage
65	0.54	0.31	0.27	0.23	0.19	0.14	
100	0.83	0.48	0.42	0.36	0.29	0.21	

ACCESSORIES



Photocell [Factory Installed] (Option) [WP-PH]



Integrated 8W Emergency Battery Backup (Not Available for 100W) [Factory Installed] (Option) [EM]