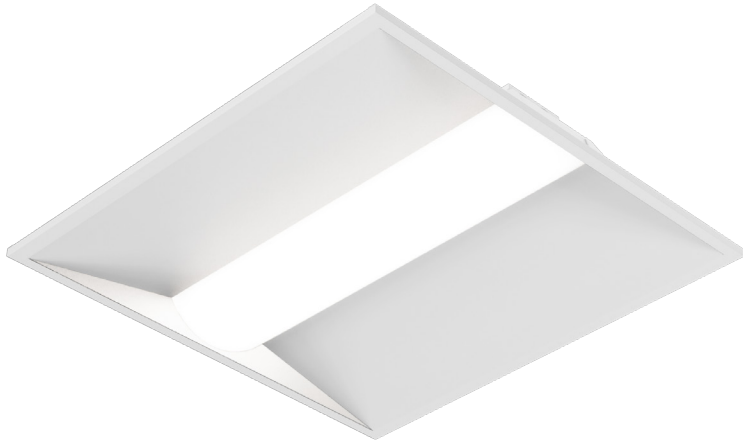

Wave™ T24 Troffer  
Troffer

Date:	
Project Name:	
SKU #:	

## APPLICATIONS

Commercial, Retail, Institution, and Hospitality

## FEATURES

## Construction

- The reflector is finished with a glare reducing matte white paint for improved aesthetics and increased light diffusion.
- End plates contain easy-to-position integral T-bar clips for securely attaching the luminaire to the T-grid.
- Steel Housing

## Electrical &amp; Technical

- Input Voltage: 100-277V
- Input Frequency: 50/60Hz
- Projected L70 > 50,000 hrs
- PF: >0.9
- CRI: >90
- THD: <20%
- CCT Selectable:  
3000K/3500K/4000K
- Operating Temp.: -40°F ~ 122°F
- 0-10V Dimming
- 8W Emergency Battery Backup [Option]
- 15W Emergency Inverter [Option]
- 10W Bodine Inverter [Option]

## Controls

- 0-10V Dimming
- Lutron Vive PowPak [Option][Factory Install]

## Lumen Output

- 1'x4':
- 24W: 3,120lm
  - 30W: 3,900lm
  - 36W: 4,680lm
- 2'x2':
- 24W: 3,120lm
  - 30W: 3,900lm
  - 36W: 4,680lm
- 2'x4':
- 24W: 3,120lm
  - 36W: 4,680lm
  - 45W: 5,850lm

## Finish

- Powder Coated Matte White

## Optical

- Extruded acrylic diffusers efficiently deliver light in a volumetric distribution.

## Installation/Mounting

- Recessed Mount [Standard]
- Flange Mount Kit

## Dimmer Compatibility List:

Leviton: IP710-DLZ, DS710  
Lutron: DVSTV-WH, MS-Z101  
Eaton: WBSD-010SLD  
LeGrand: RH4FBL3PTC  
Hubbel: LHDIRS3N

## Warranty

- 5 Year Warranty
- See warranty documentation for more information.



## ORDERING INFORMATION

EXAMPLE: WT-22-30-C-U

WT	SOLD IN 4-PACKS ONLY			
Series	Size	Wattage	CCT	Input Voltage
WT	14 - 1'x4' 22 - 2'x2'	24 - 24W 30 - 30W 36 - 36W	C - 3000K/3500K/4000K	U - 100-277V
	24 - 2'x4'	24 - 24W 36 - 36W 45 - 45W		
			Flange Mount Kit	Accessories
			8822-FMK (2x2 Flange Mount Kit) 8824-FMK (2x4 Flange Mount Kit)	EM (8W Emergency Battery Backup) ELIS10CDF (Bodine 10W Inverter) TGS-15W-INT (EM Inverter 15W) T-BR-EM (T-Bar Bracket for EM Backup) FCJSO (Lutron Vive PowPak)

## DIMENSIONS

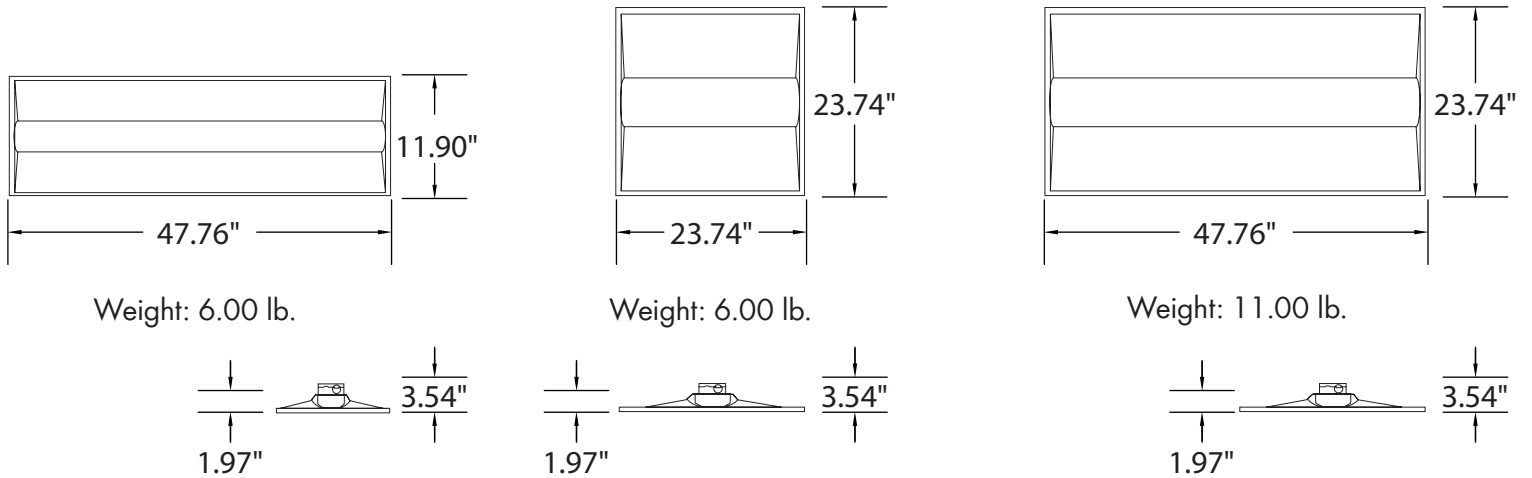

## LUMEN OUTPUT

SKU	Size (LxW)	Wattage (W)	Delivered Lumens (lm)	Efficacy (lm/W)
WT-14-24-C-U	1'x4'	24	3120	130
WT-14-30-C-U	1'x4'	30	3900	130
WT-14-36-C-U	1'x4'	36	4680	130
WT-22-24-C-U	2'x2'	24	3120	130
WT-22-30-C-U	2'x2'	30	3900	130
WT-22-36-C-U	2'x2'	36	4680	130
WT-24-24-C-U	2'x4'	24	3120	130
WT-24-36-C-U	2'x4'	36	4680	130
WT-24-45-C-U	2'x4'	45	5850	130

## ACCESSORIES



Recessed  
Mounted  
Integral Clips  
[T-bar]  
(Standard)



Flange  
Mount Kit  
2'x2', 2'x4'  
(Option)  
[8822-FMK]  
[8824-FMK]



Emergency  
Battery Backup  
8W  
(Option)  
[EM]



Bodine Inverter  
10W  
(Option)  
[ELIS10CDF]



Emergency  
Inverter 15W  
(Option)  
[TGS-15W-INT]



T-Bar Emergency  
Battery Bracket  
(Option)  
[T-BR-EM]