

Date:	
Project Name:	
SKU #:	

Wave™ Troffer
Wattage & CCT Selectable Troffer



APPLICATIONS

Commercial, Retail, Institution, and Hospitality

FEATURES

Construction

- The reflector is finished with a glare reducing matte white paint for improved aesthetics and increased light diffusion.
- End plates contain easy-to-position integral T-bar clips for securely attaching the luminaire to the T-grid.
- Steel Housing

Finish

- Powder Coated Matte White

Electrical & Technical

- Input Voltage: 100-277V
- Input Frequency: 50/60Hz
- Projected L70 > 50,000 hrs
- PF: >0.9
- CRI: >80
- THD: <20%
- CCT Selectable: 3500K/4000K/5000K
- Field Adjustable Lumen Output
- Operating Temp.: -40°F ~ 122°F
- 0-10V Dimming
- Emergency Battery Backup [Option]
[Factory Install Only For 2'x2' & 2'x4']
- 15W Emergency Inverter [Option]
- 10W Bodine Inverter [Option]

Optical

- Extruded acrylic diffusers efficiently deliver light in a volumetric distribution.

Installation/Mounting

- Recessed Mount [Standard]
- Flange Mount Kit

Dimmer Compatibility List:

- Leviton: IP710-DLZ, DS710
- Lutron: DVSTV-WH, MS-Z101
- Eaton: WBSD-010SLD
- LeGrand: RH4FBL3PTC
- Hubbel: LHDIRS3N

Controls

- 0-10V Dimming
- Lutron Vive PowPak [Option][Factory Install]

Warranty

- 5 Year Warranty
- See warranty documentation for more information.

Lumen Output

- 1'x4': 24W (3,120lm)/30W (3,900lm)/36W (4,680lm)
- 2'x2': 24W (3,120lm)/30W (3,900lm)/36W (4,680lm)
- 2'x4': 24W (3,120lm)/36W (4,680lm)/45W (5,850lm)



Not all products are qualified on the DLC® QPL. To view our DLC® qualified products, please consult the DLC® Qualified Products List at www.designlights.org/apl.

ORDERING INFORMATION **EXAMPLE: WT-22-W-C-U**

SOLD IN 4-PACKS ONLY					
Series	Size	Wattage	CCT	Input Voltage	
WT	14 - 1'x4'	W - 24W/30W/36W	C - 3500K/4000K/5000K	U - 100-277V	
	22 - 2'x2'				
	24 - 2'x4'	W - 24W/36W/45W			
SOLD IN SINGLE PACKS ONLY					
Series	Size	Wattage	CCT	Input Voltage	EM
WT	22 - 2'x2'	W - 24W/30W/36W	C - 3500K/4000K/5000K	U - 100-277V	EM - EM Backup
	24 - 2'x4'	W - 24W/36W/45W			
Accessories					
ELIS10CDF (Bodine 10W Inverter)					
TGS-15W-INT (EM Inverter 15W)					
T-BR-EM (T-Bar Bracket for EM Backup)					
FCJSO (Lutron Vive PowPak)					

DIMENSIONS

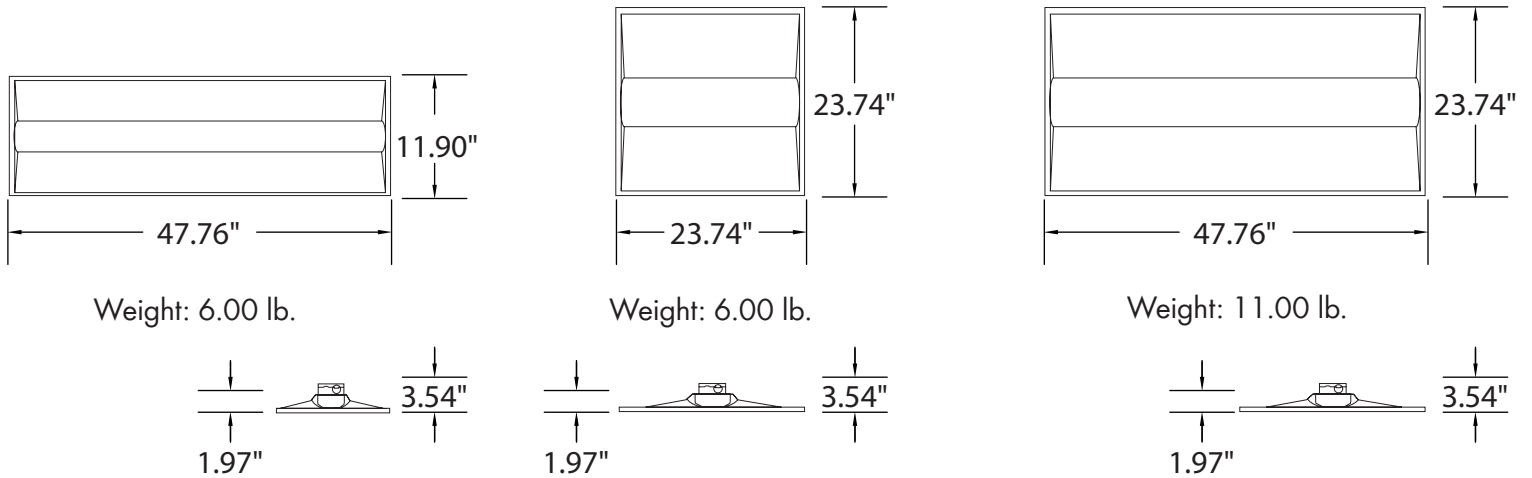

LUMEN OUTPUT

SKU	Size (LxW)	Wattage (W)	Delivered Lumens (lm)	Efficacy (lm/W)	Delivered Lumens (lm)	Efficacy (lm/W)	Delivered Lumens (lm)	Efficacy (lm/W)
WT-14-W-C-U	1'x4'	24/30/36	3120 (24W)	130	3900 (30W)	130	4680 (36W)	130
WT-22-W-C-U	2'x2'	24/30/36	3120 (24W)	130	3900 (30W)	130	4680 (36W)	130
WT-24-W-C-U	2'x4'	24/36/45	3120 (24W)	130	4680 (36W)	130	5850 (45W)	130

ACCESSORIES

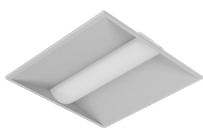

Recessed Mounted
Integral Clips
[T-bar]
(Standard)



Emergency
Battery Backup
[Factory Install Only]
[For 2'x2' & 2'x4']
(Option)
[EM]



Bodine Inverter
10W
(Option)
[ELIS10CDF]



Emergency
Inverter 15W
(Option)
[TGS-15W-INT]



T-Bar Emergency
Battery Bracket
(Option)
[T-BR-EM]



Lutron Vive
PowPak
[Factory Install]
(Option)
[FCJS0]