

Date:	
Project Name:	
SKU #:	

**Wave™ Troffer**  
Wattage & CCT Selectable Troffer



**APPLICATIONS**

Commercial, Retail, Institution, and Hospitality

**FEATURES**

**Construction**

- The reflector is finished with a glare reducing matte white paint for improved aesthetics and increased light diffusion.
- End plates contain easy-to-position integral T-bar clips for securely attaching the luminaire to the T-grid.
- Steel Housing

**Finish**

- Powder Coated Matte White

**Electrical & Technical**

- Input Voltage: 100-277V
- Input Frequency: 50/60Hz
- Projected L70 > 50,000 hrs
- PF: >0.9
- CRI: >80
- THD: <20%
- CCT Selectable: 3500K/4000K/5000K
- Field Adjustable Lumen Output
- Operating Temp.: -40°F ~ 122°F
- 0-10V Dimming
- Emergency Battery Backup [Option]  
[Factory Install Only For 2'x2' & 2'x4']
- 15W Emergency Inverter [Option]
- 10W Bodine Inverter [Option]

**Optical**

- Extruded acrylic diffusers efficiently deliver light in a volumetric distribution.

**Installation/Mounting**

- Recessed Mount [Standard]
- Flange Mount Kit

**Dimmer Compatibility List:**

- Leviton: IP710-DLZ, DS710
- Lutron: DVSTV-WH, MS-Z101
- Eaton: WBSD-010SLD
- LeGrand: RH4FBL3PTC
- Hubbel: LHDIRS3N

**Controls**

- 0-10V Dimming
- Lutron Vive PowPak [Option][Factory Install]

**Warranty**

- 5 Year Warranty
- See warranty documentation for more information.

**Lumen Output**

- 1'x4': 24W (3,120lm)/30W (3,900lm)/36W (4,680lm)
- 2'x2': 24W (3,120lm)/30W (3,900lm)/36W (4,680lm)
- 2'x4': 24W (3,120lm)/36W (4,680lm)/45W (5,850lm)



Not all products are qualified on the DLC® QPL. To view our DLC® qualified products, please consult the DLC® Qualified Products List at [www.designlights.org/qpl](http://www.designlights.org/qpl).

**ORDERING INFORMATION** **EXAMPLE: WT-22-W-C-U**

WT		SOLD IN 4-PACKS ONLY				
Series	Size	Wattage	CCT	Input Voltage		
WT	14 - 1'x4'	W - 24W/30W/36W	C - 3500K/4000K/5000K	U - 100-277V		
	22 - 2'x2'					
WT	24 - 2'x4'	W - 24W/36W/45W				
	<b>SOLD IN SINGLE PACKS ONLY FOR EMERGENCY BATTERY BACK</b>					EM
Series	Size	Wattage	CCT	Input Voltage	EM	
WT	22 - 2'x2'	W - 24W/30W/36W	C - 3500K/4000K/5000K	U - 100-277V	EM - EM Backup	
	24 - 2'x4'	W - 24W/36W/45W				

**NOTE: Single Packs are only available for Emergency Battery Backup Version**

- Accessories**
- ELIS10CDF (Bodine 10W Inverter)
  - TGS-15W-INT (EM Inverter 15W)
  - T-BR-EM (T-Bar Bracket for EM Backup)
  - FCJSO (Lutron Vive PowPak)

## DIMENSIONS

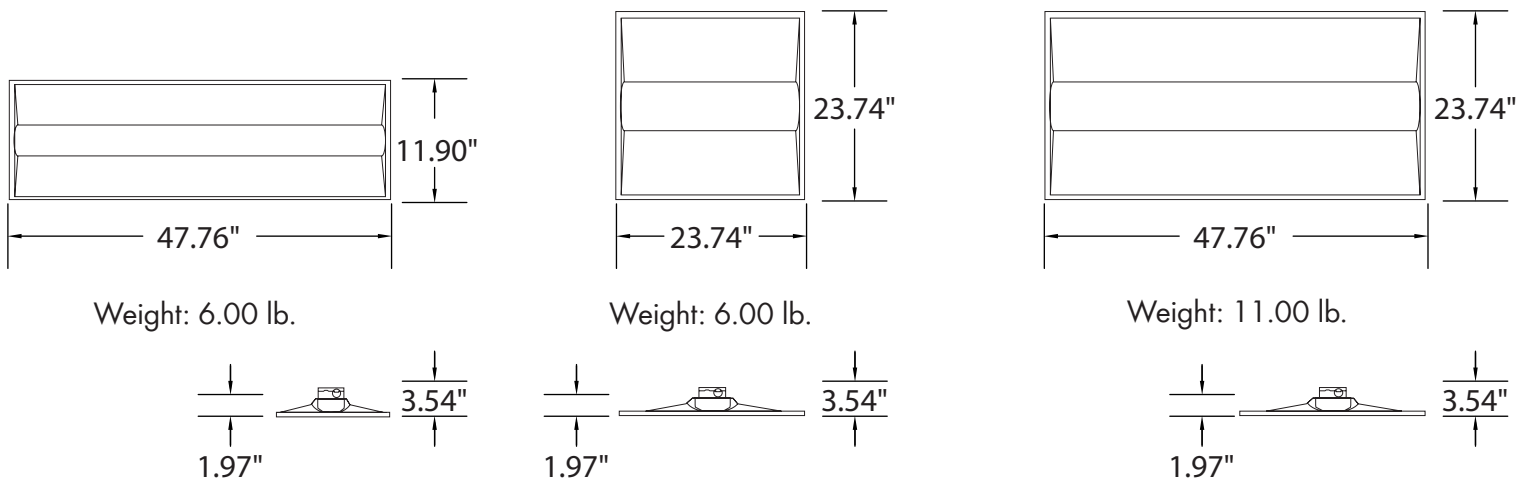

## LUMEN OUTPUT

SKU	Size (LxW)	Wattage (W)	Delivered Lumens (lm)	Efficacy (lm/W)	Delivered Lumens (lm)	Efficacy (lm/W)	Delivered Lumens (lm)	Efficacy (lm/W)
WT-14-W-C-U	1'x4'	24/30/36	3120 (24W)	130	3900 (30W)	130	4680 (36W)	130
WT-22-W-C-U	2'x2'	24/30/36	3120 (24W)	130	3900 (30W)	130	4680 (36W)	130
WT-24-W-C-U	2'x4'	24/36/45	3120 (24W)	130	4680 (36W)	130	5850 (45W)	130

## ACCESSORIES



Recessed Mounted Integral Clips [T-bar] (Standard)



Emergency Battery Backup [Factory Install Only] [For 2'x2' & 2'x4'] (Option) [EM]



Bodine Inverter 10W (Option) [ELIS10CDF]



Emergency Inverter 15W (Option) [TGS-15W-INT]



T-Bar Emergency Battery Bracket (Option) [T-BR-EM]



Lutron Vive PowPak [Factory Install] (Option) [FCJS0]