

Date:	
Project Name:	
SKU #:	

Eco AIR™ LC
Premium Backlit Panel

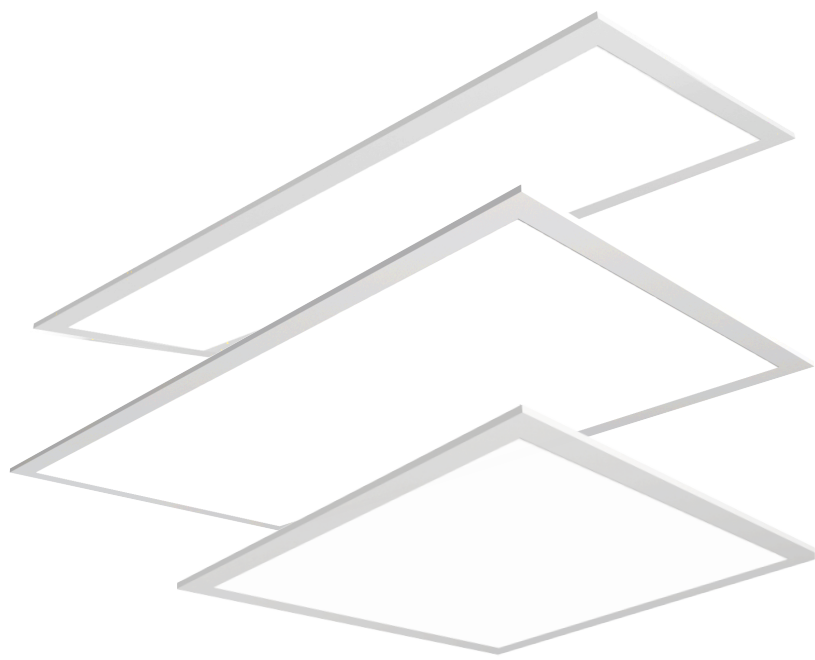

APPLICATIONS

Commercial, Retail, Institution, and Hospitality

FEATURES

- | | |
|--|--|
| <p>Construction</p> <ul style="list-style-type: none"> - Aluminum Frame & Steel Backing with Integral Earthquake Clips | <p>Finish</p> <ul style="list-style-type: none"> - White |
| <p>Electrical & Technical</p> <ul style="list-style-type: none"> - Input Voltage: 120-277VAC - Input Frequency: 50/60Hz - Projected L70 > 50,000 hrs - PF: >0.9 - CRI: >80 - THD: <20% - CCT Selectable: 3500K/4000K/5000K - Operating Temp.: -4°F ~ 122°F - Class 2 Isolated Driver with 0-10V Dimming & 1.2kV Surge Protection - Damp Location Rated - 8W Emergency Battery Backup [Option] - 15W Emergency Inverter [Option] - 10W Bodine Inverter [Option] | <p>Optical</p> <ul style="list-style-type: none"> - Acrylic Modular Optic Frosted Diffuser |
| <p>Controls</p> <ul style="list-style-type: none"> - 0-10V Dimming (Dims to 10%) Isolated Dimming Control Driver. [Meets Updated UL8750 Requirement for Separation of Control circuit.] - Microwave Bi-level Occupancy/Daylight Harvesting Sensor [Option] - Lutron Vive PowPak [Option][Factory Install] | <p>Installation/Mounting</p> <ul style="list-style-type: none"> - Recessed Mount [Standard] - Surface Mount Kit - Flange Mount Kit |
| <p>Lumen Output</p> <ul style="list-style-type: none"> • 1'x4': 20W (2,500lm)
25W (3,125lm)
30W (3,750lm) • 2'x2': 20W (2,500lm)
30W (3,750lm)
40W (5,000lm) • 2'x4': 40W (5,000lm)
50W (6,250lm)
55W (6,875lm) | <p>Warranty</p> <ul style="list-style-type: none"> - 5 Year Warranty See warranty documentation for more information. |



ORDERING INFORMATION **EXAMPLE: EA-P-14-L-C-U-D**

Series	Size	Lumen Output	CCT	Input Voltage	Dimming	Control Option	EM Option
EA-P	14 - 1'x4'	L - 20W/25W/30W	C - 3500K/4000K/5000K	U - 120~277V	D - 0~10V Dimming	M - Bi-level Occupancy/Daylight Harvesting Sensor	EM - 8W EM Backup
	22 - 2'x2'	L - 20W/30W/40W					
	24 - 2'x4'	L - 40W/50W/55W					
		Surface Mount Kit		Flange Mount Kit		Accessories	
		8814-SK (1x4 Surface Mount Kit)		8814-FMK (1x4 Flange Mount Kit)		88-WP8-3C (8': 3 Wire Whip [18AWG])	
		8822-SK (2x2 Surface Mount Kit)		8822-FMK (2x2 Flange Mount Kit)		T-BR-EM (T-Bar Bracket For Emergency Battery Backup)	
		8824-SK (2x4 Surface Mount Kit)		8824-FMK (2x4 Flange Mount Kit)		ELIS10CDF (10W Bodine Inverter)	
						TGS-15W-INT (15W Emergency Inverter)	
						FCJS0 (Lutron Vive PowPak)	

DIMENSIONS

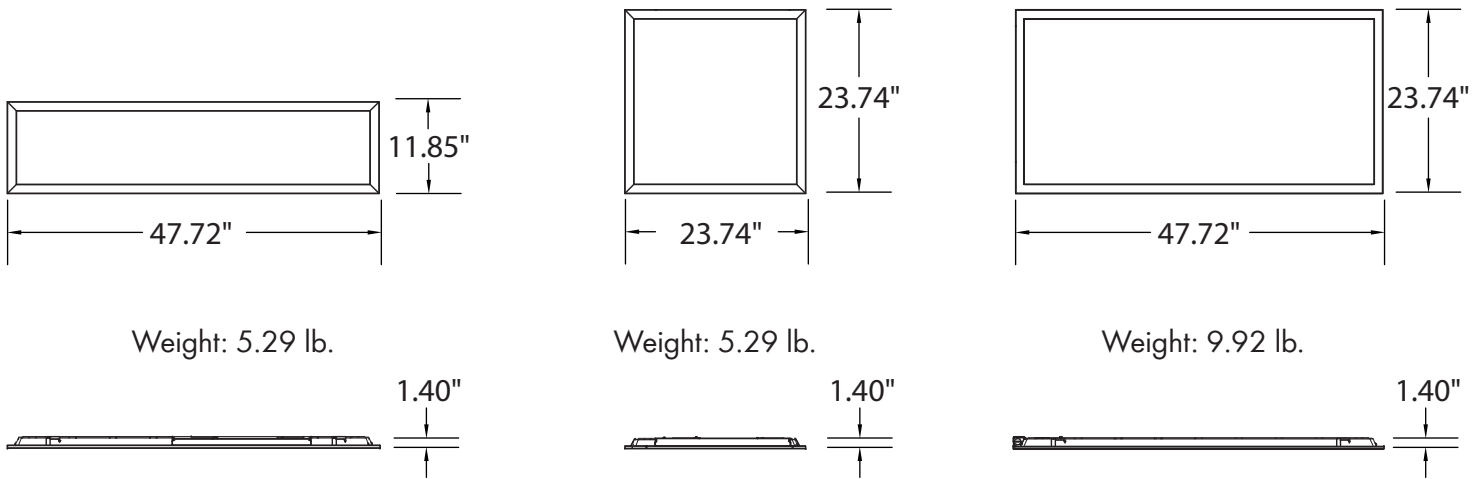

LUMEN OUTPUT

SKU	Size (LxW)	Wattage (W)	Delivered Lumens (lm)	Efficacy (lm/W)	Delivered Lumens (lm)	Efficacy (lm/W)	Delivered Lumens (lm)	Efficacy (lm/W)
EA-P-14-L-C-U-D	1'x4'	20/25/30	2500 (20W)	125	3125 (25W)	125	3750 (30W)	125
EA-P-22-L-C-U-D	2'x2'	20/30/40	2500 (20W)	125	3750 (30W)	125	5000 (40W)	125
EA-P-24-L-C-U-D	2'x4'	40/50/55	5000 (40W)	125	6250 (50W)	125	6875 (55W)	125

ACCESSORIES

