

Date:	
Project Name:	
SKU #:	

**Wave™ Troffer**  
Wattage & CCT Selectable Troffer



**APPLICATIONS**

Commercial, Retail, Institution, and Hospitality

**FEATURES**

**Construction**

- The reflector is finished with a glare reducing matte white paint for improved aesthetics and increased light diffusion.
- End plates contain easy-to-position integral T-bar clips for securely attaching the luminaire to the T-grid.
- Steel Housing

**Finish**

- Powder Coated Matte White

**Electrical & Technical**

- Input Voltage: 100-277V
- Input Frequency: 50/60Hz
- Projected L70 > 50,000 hrs
- PF: >0.9
- CRI: >80
- THD: <20%
- CCT Selectable: 3500K/4000K/5000K
- Field Adjustable Lumen Output
- Operating Temp.: -40°F ~ 122°F
- 0-10V Dimming
- 8W Emergency Battery Backup [Option]
- 15W Emergency Inverter [Option]
- 10W Bodine Inverter [Option]

**Optical**

- Extruded acrylic diffusers efficiently deliver light in a volumetric distribution.

**Installation/Mounting**

- Recessed Mount [Standard]
- Flange Mount Kit

**Dimmer Compatibility List:**

- Leviton: IP710-DLZ, DS710
- Lutron: DVSTV-WH, MS-Z101
- Eaton: WBSD-010SLD
- LeGrand: RH4FBL3PTC
- Hubbel: LHDIRS3N

**Controls**

- 0-10V Dimming

**Warranty**

- 5 Year Warranty
- See warranty documentation for more information.

**Lumen Output**

- 1'x4': 24W (3,120lm)/30W (3,900lm)/36W (4,680lm)
- 2'x2': 24W (3,120lm)/30W (3,900lm)/36W (4,680lm)
- 2'x4': 24W (3,120lm)/36W (4,680lm)/45W (5,850lm)

Not all products are qualified on the DLC® QPL. To view our DLC® qualified products, please consult the DLC® Qualified Products List at [www.designlights.org/qpl](http://www.designlights.org/qpl).



**ORDERING INFORMATION** **EXAMPLE: WT-22-W-C-U**

WT		SOLD IN 4-PACKS ONLY		
Series	Size	Wattage	CCT	Input Voltage
WT	14 - 1'x4' 22 - 2'x2'	W - 24W/30W/36W	C - 3500K/4000K/5000K	U - 100-277V
	24 - 2'x4'	W - 24W/36W/45W		
		<b>Flange Mount Kit</b>	<b>Accessories</b>	
		8822-FMK (2x2 Flange Mount Kit) 8824-FMK (2x4 Flange Mount Kit)	EM (8W Emergency Battery Backup) ELIS10CDF (Bodine 10W Inverter) TGS-15W-INT (EM Inverter 15W) T-BR-EM (T-Bar Bracket for EM Backup)	

**DIMENSIONS**

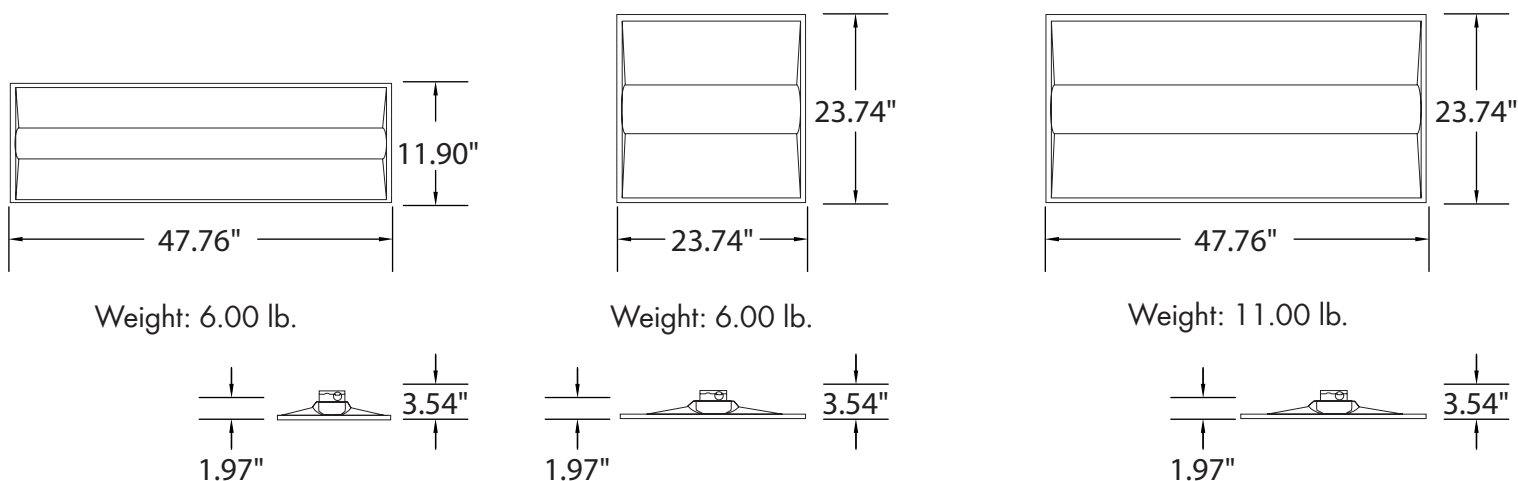

**LUMEN OUTPUT**

SKU	Size (LxW)	Wattage (W)	Delivered Lumens (lm)	Efficacy (lm/W)	Delivered Lumens (lm)	Efficacy (lm/W)	Delivered Lumens (lm)	Efficacy (lm/W)
WT-14-W-C-U	1'x4'	24/30/36	3120 (24W)	130	3900 (30W)	130	4680 (36W)	130
WT-22-W-C-U	2'x2'	24/30/36	3120 (24W)	130	3900 (30W)	130	4680 (36W)	130
WT-24-W-C-U	2'x4'	24/36/45	3120 (24W)	130	4680 (36W)	130	5850 (45W)	130

**ACCESSORIES**

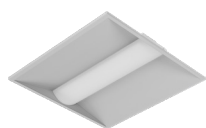

Recessed Mounted Integral Clips [T-bar] (Standard)



Flange Mount Kit 2'x2', 2'x4' (Option) [8822-FMK] [8824-FMK]



Emergency Battery Backup 8W (Option) [EM]



Bodine Inverter 10W (Option) [ELIS10CDF]



Emergency Inverter 15W (Option) [TGS-15W-INT]



T-Bar Emergency Battery Bracket (Option) [T-BR-EM]