



COMBINED FAMILY SPECIFICATION

EM BATTERY BACKUP

LED Emergency Battery Backup

EM Battery Backup - Low Voltage

EM Battery Backup - High Voltage



SKU#: _____ PROJECT NAME: _____ DATE: _____

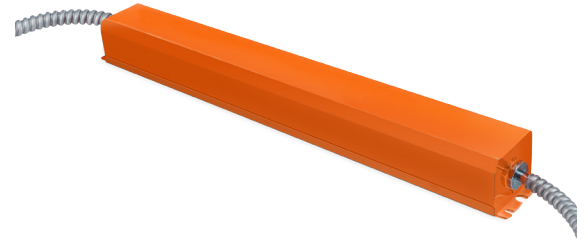

Low Voltage LED Emergency Battery Backup

DESCRIPTION

The Low-Voltage LED Emergency Battery Backup is an invaluable addition to your LED luminaires. In the event of a power failure, it switches to emergency mode and powers LED lights with external drivers. The device output is 15V-54V DC and is suitable for use with 100-277 VAC devices. The TGS Low Voltage Emergency Battery Backup maintains illumination at a constant level for up to 90 minutes.

Three models are available for fixtures with an output power of 8W, and 25W. It is UL listed and meets or exceeds all National Electrical Code and Life Safety Code Emergency Lighting standards. The TGS Solutions Low-Voltage LED Emergency Battery Backup is covered by a 5-year warranty.

LV-EM

8W (90008-L)
25W (90025-L)



Technical Details

	8W	25W
Output Power	8W	25W
Output Voltage	15-54VC DC	18-54VC DC
Input Current	70mA (Max)	110mA (Max)
Input Power	3.2W (Max)	6W (Max)
Input Voltage	100-277VAC ,50-60Hz	100-277VAC ,50-60Hz
Emergency Operation	≥90 Minutes	≥90 Minutes
Operating Temp.	32°F~122°F	32°F~122°F
Output Class	UL LELV (Ouput protection self resetting)	UL LELV (Ouput protection self resetting)
Battery	Lithium	Lithium
Recharge	24Hrs	36Hrs
Dimension	L: 10.64x1.98x1.32"	L: 15.40"xW: 2.13"xH: 1.57"

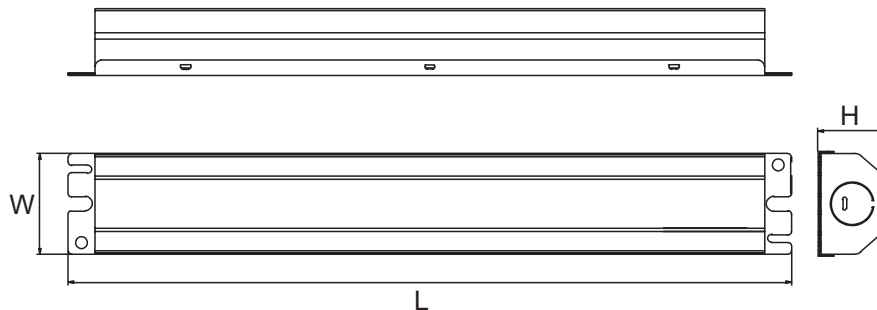

Ordering Information

EXAMPLE: 90008-L

SERIES	Wattage	Type
900	08 - 8W 25 - 25W	L - Low Voltage

Specifications and Dimensions subject to change without notice.

*MOQ and longer lead times may apply, please contact customer service for more information.

Low Voltage LED Emergency Battery Backup

Wiring Diagram

8W

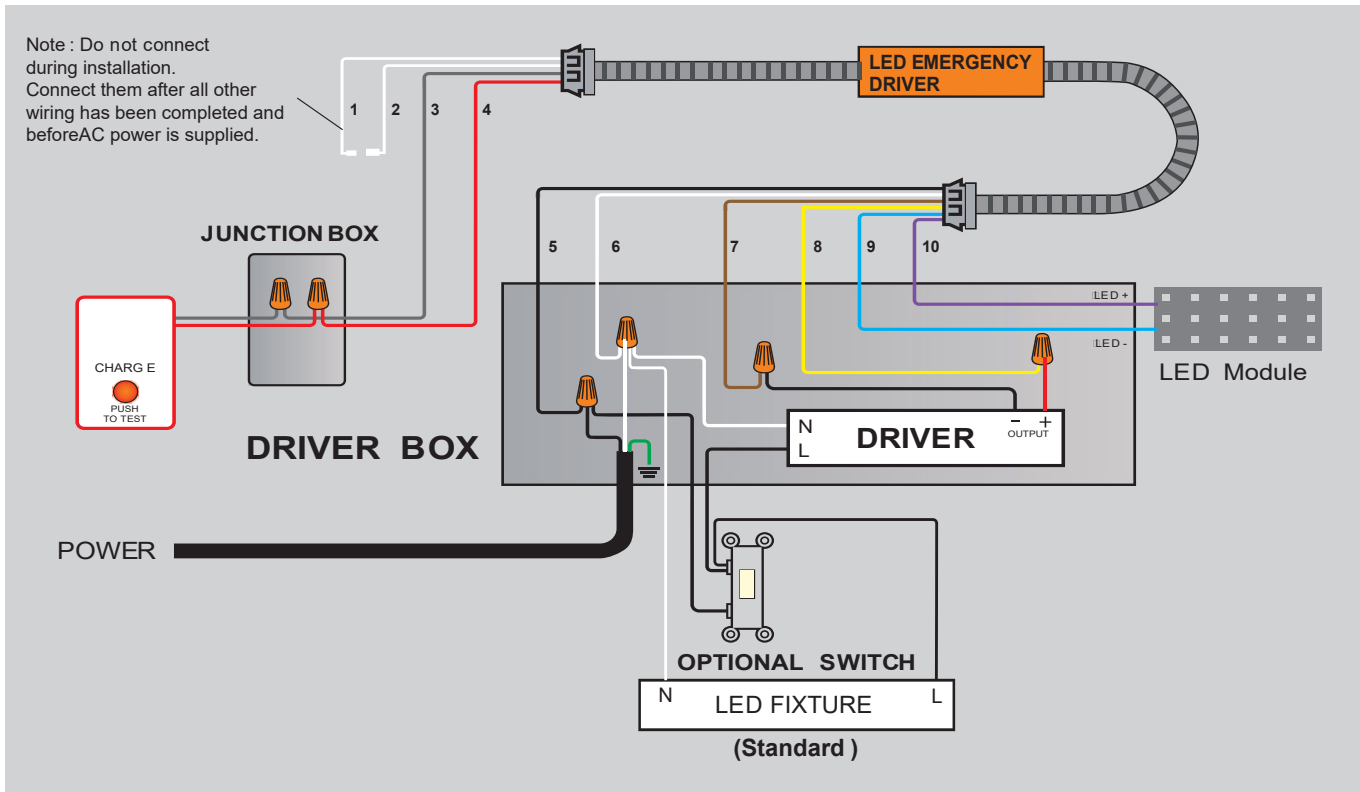

25W

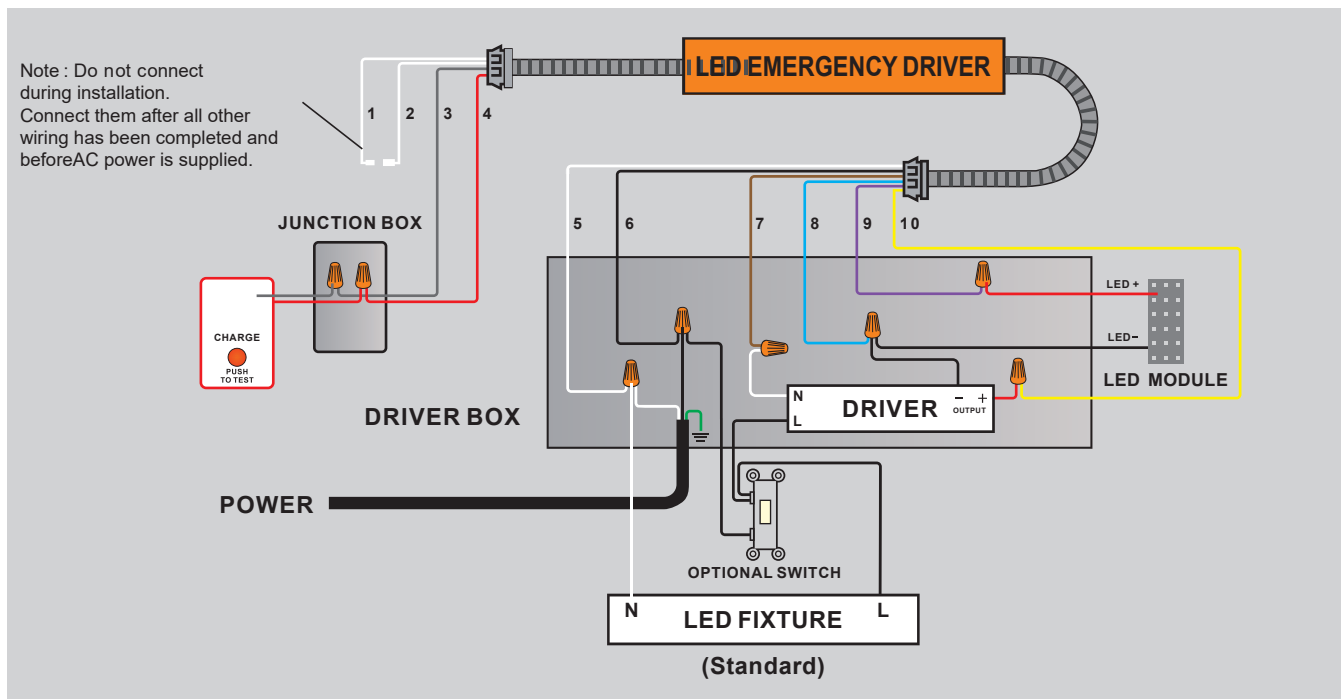

Yellow Wire Current: 4A(Max)

Date:	
Project Name:	
SKU #:	

High Voltage Emergency Battery Backup

LED Emergency Battery Backup

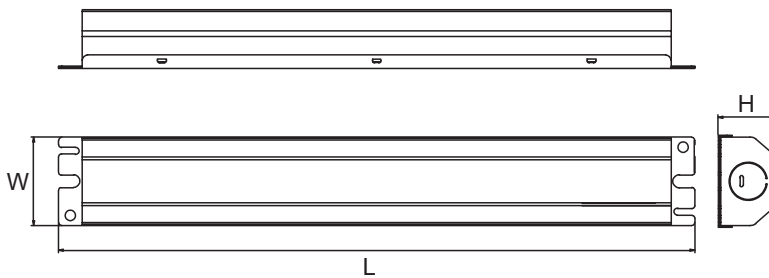

DESCRIPTION

The High-Voltage LED Emergency Battery Backup is an invaluable addition to your LED luminaires. In the event of a power failure, it switches to emergency mode and powers LED lights with external drivers. The device output is 170V DC and is suitable for use with 100-277 VAC devices. The TGS High Voltage Emergency Battery Backup maintains illumination at a constant level for up to 90 minutes.

Three models are available for fixtures with an output power of 8W or 25W. It is UL listed and meets or exceeds all National Electrical Code and Life Safety Code Emergency Lighting standards. The TGS Solutions High-Voltage LED Emergency Battery Backup is covered by a 5-year warranty.

TECHNICAL DETAILS

Output Power	8W	25W
Output Voltage	170V DC	170V DC
Input Current	70mA (Max)	110mA (Max)
Input Power	3.2W (Max)	6W (Max)
Input Voltage	100-277VAC, 50/60Hz	100-277VAC, 50/60Hz
Emergency Operation	≥90 Minutes	≥90 Minutes
Operating Temp.	32°F~122°F	32°F~122°F
Output Class	UL LELV (Output protection self resetting)	UL LELV (Output protection self resetting)
Battery	Lithium	Lithium
Recharge	24Hrs	36Hrs
Dimension L x W x H	12.76" x 12.13" x 1.57"	15.14" x 2.13" x 1.57"



ORDERING INFORMATION

900		
Series	Size/Wattage	Type
900	08 - 8W 25 - 25W	H - High Voltage

WIRING DIAGRAM

