

Date:	
Project Name:	
SKU #:	

Wave™ T24 Troffer
Troffer

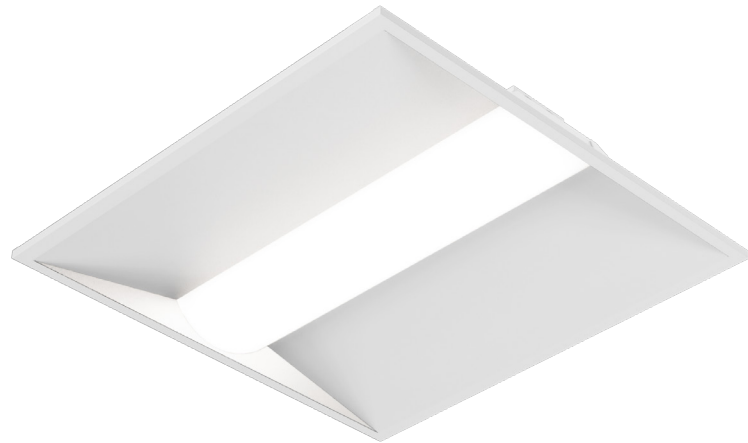

APPLICATIONS

Commercial, Retail, Institution, and Hospitality

FEATURES

Construction

- The reflector is finished with a glare reducing matte white paint for improved aesthetics and increased light diffusion.
- End plates contain easy-to-position integral T-bar clips for securely attaching the luminaire to the T-grid.
- Steel Housing

Finish

- Powder Coated Matte White

Electrical & Technical

- Input Voltage: 100-277V
- Input Frequency: 50/60Hz
- Projected L70 > 50,000 hrs
- PF: >0.9
- CRI: >90
- THD: <20%
- CCT Selectable: 3000K/3500K/4000K
- Operating Temp.: -40°F ~ 122°F
- 0-10V Dimming
- 8W Emergency Battery Backup [Option]
- 15W Emergency Inverter [Option]
- 10W Bodine Inverter [Option]

Optical

- Extruded acrylic diffusers efficiently deliver light in a volumetric distribution.

Installation/Mounting

- Recessed Mount [Standard]
- Flange Mount Kit

Controls

- 0-10V Dimming

Dimmer Compatibility List:

- Leviton: IP710-DLZ, DS710
- Lutron: DVSTV-WH, MS-Z101
- Eaton: WBSD-010SLD
- LeGrand: RH4FBL3PTC
- Hubbel: LHDIRS3N

Lumen Output

- 1'x4':
- 24W: 3,120lm
 - 30W: 3,900lm
 - 36W: 4,680lm
- 2'x2':
- 24W: 3,120lm
 - 30W: 3,900lm
 - 36W: 4,680lm
- 2'x4':
- 24W: 3,120lm
 - 36W: 4,680lm
 - 45W: 5,850lm

Warranty

- 5 Year Warranty
- See warranty documentation for more information.



ORDERING INFORMATION **EXAMPLE: WT-22-30-C-U**

WT	SOLD IN 4-PACKS ONLY				
Series	Size	Wattage	CCT	Input Voltage	
WT	14 - 1'x4'	24 - 24W	C - 3000K/3500K/4000K	U - 100-277V	
	22 - 2'x2'	30 - 30W			
		36 - 36W			
	24 - 2'x4'	24 - 24W			
		36 - 36W			
		45 - 45W			

Flange Mount Kit	Accessories
8822-FMK (2x2 Flange Mount Kit)	EM (8W Emergency Battery Backup)
8824-FMK (2x4 Flange Mount Kit)	ELIS10CDF (Bodine 10W Inverter)
	TGS-15W-INT (EM Inverter 15W)
	T-BR-EM (T-Bar Bracket for EM Backup)

DIMENSIONS

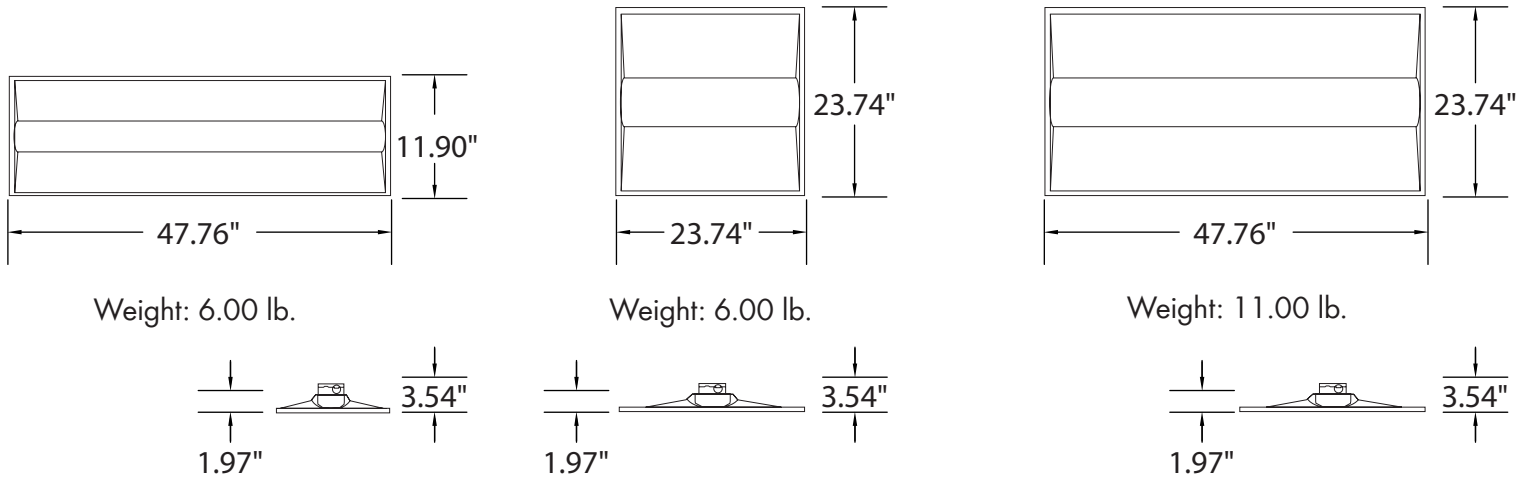

LUMEN OUTPUT

SKU	Size (LxW)	Wattage (W)	Delivered Lumens (lm)	Efficacy (lm/W)
WT-14-24-C-U	1'x4'	24	3120	130
WT-14-30-C-U	1'x4'	30	3900	130
WT-14-36-C-U	1'x4'	36	4680	130
WT-22-24-C-U	2'x2'	24	3120	130
WT-22-30-C-U	2'x2'	30	3900	130
WT-22-36-C-U	2'x2'	36	4680	130
WT-24-24-C-U	2'x4'	24	3120	130
WT-24-36-C-U	2'x4'	36	4680	130
WT-24-45-C-U	2'x4'	45	5850	130

ACCESSORIES



Recessed Mounted Integral Clips [T-bar] (Standard)



Flange Mount Kit 2'x2', 2'x4' (Option) [8822-FMK] [8824-FMK]



Emergency Battery Backup 8W (Option) [EM]



Bodine Inverter 10W (Option) [ELIS10CDF]



Emergency Inverter 15W (Option) [TGS-15W-INT]



T-Bar Emergency Battery Bracket (Option) [T-BR-EM]