

Date:	
Project Name:	
SKU #:	

**ThinTek™ Wafer S**  
Recessed Downlight



**APPLICATIONS**

Residential, Commercial, Multi-Family Complex

**FEATURES**

**Construction**

- Die-cast Aluminum Housing

**Electrical & Technical**

- Input Voltage: 120VAC
- Input Frequency: 60Hz
- Projected Life: L70 > 50,000 hrs
- PF: >0.9
- CRI: >90
- THD: <20%
- CCT Selectable: 2700K/3000K/3500K/4000K/5000K
- Operating Temp.: -4°F ~ 104°F
- Wet Location Rated

**Finish**

- White Trim [Standard]
- Nickel Trim\*
- Black Trim\*
- Bronze Trim\*

**Optical**

- 110° Beam Angle

**Installation/Mounting**

- Recessed Mount [Standard]: Spring loaded retention tabs

**Controls**

- Triac Dimming

**Compliance**

- JA8 TITLE 24 Compliant

**Dimmer Compatibility List:**

Leviton: 6674, 6633-P, 6683, 6672, IPL06, VP106, DB33K1, 1F4205, 1A2305  
Lutron: NT-1000, S-603P, S-600P, CTCL-153P, DVW-603PGH-WH, 4X603, DVCL-163P-WH, CTCL-153PDH-WH, SLV-600P-WH, DV-600P, CT-603PGH,WH, MIR-600THW-WH, CACL-153M-WH

**Lumen Output**

- 3"/6W: 420lm
- 4"/12W: 750lm
- 6"/15W: 1,050lm
- 8"/20W: 1,550lm
- 12"/24W: 1,900lm

**Warranty**

- 5 Year Warranty  
See warranty documentation for more information.

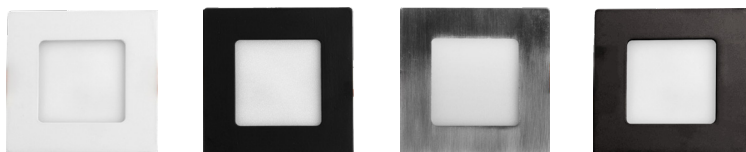

White Finish  
[Standard]

Black Finish

Nickel Finish

Bronze Finish



**ORDERING INFORMATION** **EXAMPLE: TWSF-0412-C-S**

TWSF				
Series	Size/Wattage	CCT	Input Voltage/Control	Trim Finish Option
TWSF	0306 - 3"/6W 0412 - 4"/12W 0615 - 6"/15W 0820 - 8"/20W 1224 - 12"/24W	C - 2700K/3000K/3500K/4000K/5000K	S - 120V/Triac Dimming	WH - White NI - Nickel* BK - Black* BR - Bronze*

**Accessories**

- TW-EC-A (10" Extension Cable)
- TW-EC-B (20" Extension Cable)

**DIMENSIONS**

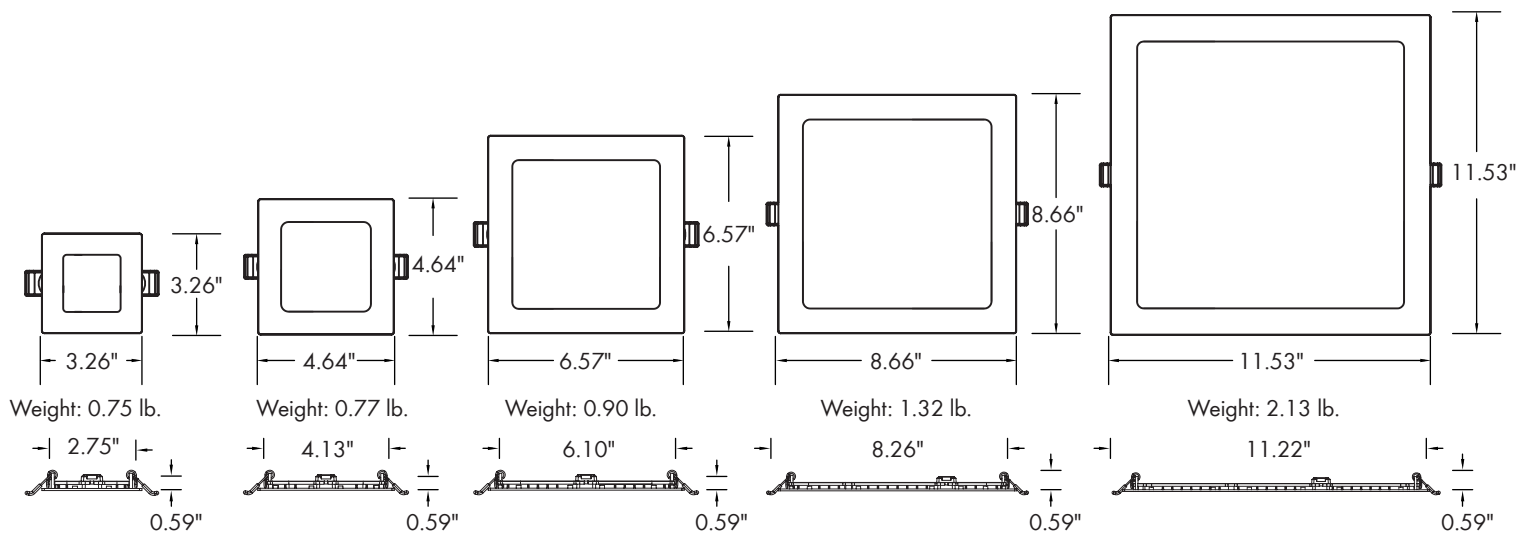

ThinTek™ Wafer 3" Driver Box Dimension:

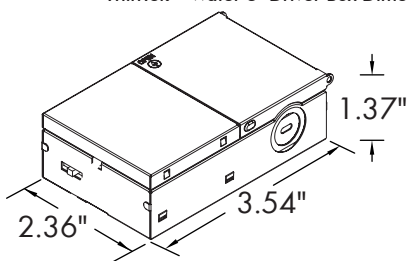

ThinTek™ Wafer 4", 6", 8", 12" Driver Box Dimension:

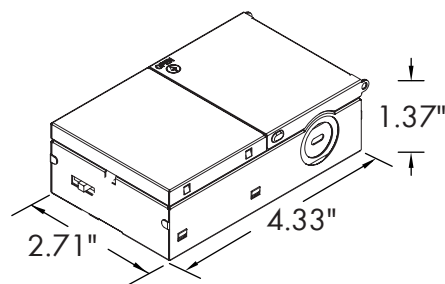

**LUMEN OUTPUT**

SKU	Size (in)	Wattage (W)	Delivered Lumens (lm)	Efficacy (lm/W)
TWSF-0306-C-S	3	6	420	70
TWSF-0412-C-S	4	12	750	62
TWSF-0615-C-S	6	15	1050	70
TWSF-0820-C-S	8	20	1550	77
TWSF-1224-C-S	12	24	1900	79

**ACCESSORIES**



Spring Loaded Retention Tabs  
Recessed Mounted  
(Standard)



10" or 20"  
Extension Cable  
(Option)  
[TW-EC-A]  
[TW-EC-B]