

Date:	
Project Name:	
SKU #:	

**Eco EDGE™ LC 130**  
Wattage & Color Selectable Edgelit Panel



**APPLICATIONS**

Commercial, Retail, Institution, and Hospitality

**FEATURES**

**Construction**

- Aluminum Housing
- PMMA Acrylic Light Guide Plate

**Finish**

- White Trim

**Electrical & Technical**

- Input Voltage: 100-277VAC
- Input Frequency: 50/60Hz
- Projected L70 > 50,000 hrs
- PF: >0.9
- CRI: >80 or >90\* [Option]
- THD: <20%
- CCT Selectable: 3500K/4000K/5000K
- Field-Adjustable Lumen Output Switch
- Operating Temp.: -4°F ~ 122°F
- Damp Location Rated
- Emergency Battery Backup Driver [Option]
- 15W Emergency Inverter [Option]
- 10W Bodine Inverter [Option]

**Optical**

- 120° Beam Angle

**Installation/Mounting**

- Recessed Mounted [Standard]
- Surface Mount Kit
- Flange Mount Kit

**Controls**

- 0-10V Dimming

**Lumen Output**

- 1'x4' & 2'x2':
  - 20W (2,500lm)
  - 30W (3,750lm)
  - 40W (5,000lm)
- 2'x4':
  - 30W (3,750lm)
  - 40W (5,000lm)
  - 50W (6,250lm)

**Warranty**

- 5 Year Warranty
- See warranty documentation for more information.



**ORDERING INFORMATION** **EXAMPLE: 8822WS-C-L-F**

88					
Panel	Size	Wattage	CCT	Series	CRI Option
88	14 - 1'x4' 22 - 2'x2'	WS - 20W/30W/40W	C - 3500K/4000K/5000K	L-F	90CRI*
	24 - 2'x4'	WS - 30W/40W/50W			
		Surface Mount Kit	Flange Mount Kit	Accessories	
		8814-SK (1x4 Surface Mount Kit) 8822-SK (2x2 Surface Mount Kit) 8824-SK (2x4 Surface Mount Kit)	8814-FMK (1x4 Flange Mount Kit) 8822-FMK (2x2 Flange Mount Kit) 8824-FMK (2x4 Flange Mount Kit)	88-WP8-3C (8': 3 Wire Whip [18AWG]) 88-WP8-5C (8': 5 Wire Whip [18AWG]) 90008-L (8W Low Voltage Emergency Battery Backup) T-BR-EM (T-Bar Bracket For Emergency Battery Backup) ELIS10CDF (10W Bodine Inverter) TGS-15W-INT (15W Emergency Inverter)	

## DIMENSIONS

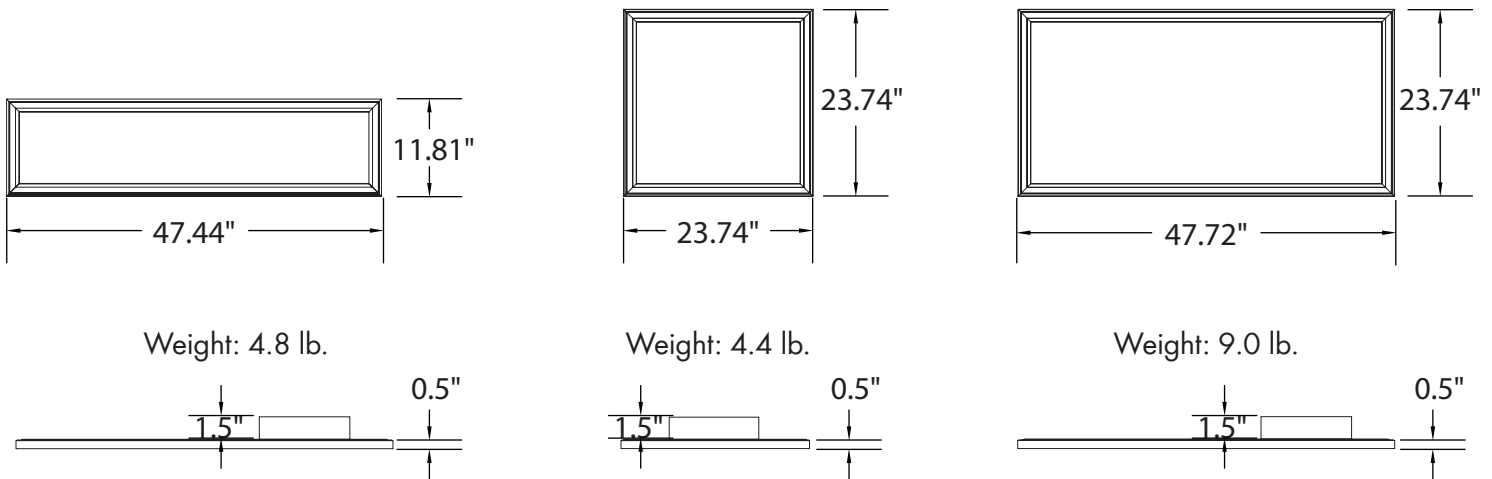

## LUMEN OUTPUT

SKU	Size (LxW)	Wattage (W)	Delivered Lumens (lm)	Efficacy (lm/W)	Delivered Lumens (lm)	Efficacy (lm/W)	Delivered Lumens (lm)	Efficacy (lm/W)
8814WS-C-LF	1'x4'	20/30/40	2500 (20W)	125	3750 (30W)	125	5000 (40W)	125
8822WS-C-LF	2'x2'	20/30/40	2500 (20W)	125	3750 (30W)	125	5000 (40W)	125
8824WS-C-LF	2'x4'	30/40/50	3750 (30W)	125	5000 (40W)	125	6250 (50W)	125

## ACCESSORIES

