

Date:	
Project Name:	
SKU #:	

Wave™ T24 Troffer
Troffer

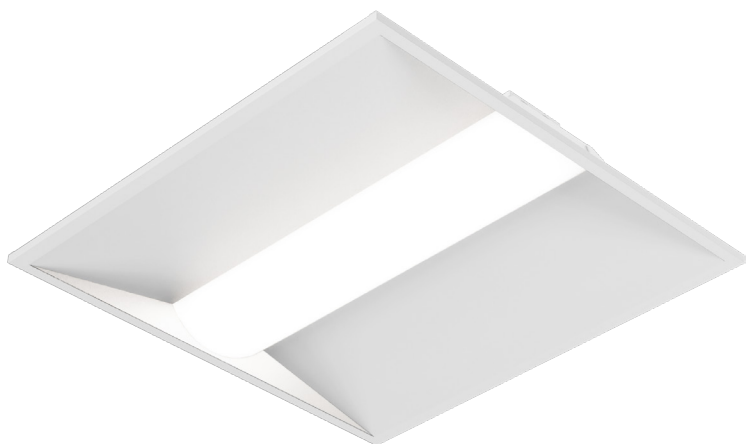

APPLICATIONS

Commercial, Retail, Institution, and Hospitality

FEATURES

Construction

- The reflector is finished with a glare reducing matte white paint for improved aesthetics and increased light diffusion.
- End plates contain easy-to-position integral T-bar clips for securely attaching the luminaire to the T-grid.
- Steel Housing

Electrical & Technical

- Input Voltage: 100-277V
- Input Frequency: 50/60Hz
- Projected L70 > 50,000 hrs
- PF: >0.9
- CRI: >90
- THD: <20%
- CCT Selectable: 3000K/3500K/4000K
- Operating Temp.: -40°F ~ 122°F
- 0-10V Dimming
- Emergency Battery Backup [Option] [Factory Install Only For 2'x2' & 2'x4']
- 15W Emergency Inverter [Option]
- 10W Bodine Inverter [Option]

Controls

- 0-10V Dimming
- Lutron Vive PowPak [Option][Factory Install]

Lumen Output

- 1'x4':
- 24W: 3,120lm
 - 30W: 3,900lm
 - 36W: 4,680lm
- 2'x2':
- 24W: 3,120lm
 - 30W: 3,900lm
 - 36W: 4,680lm
- 2'x4':
- 24W: 3,120lm
 - 36W: 4,680lm
 - 45W: 5,850lm

Finish

- Powder Coated Matte White

Optical

- Extruded acrylic diffusers efficiently deliver light in a volumetric distribution.

Installation/Mounting

- Recessed Mount [Standard]
- Flange Mount Kit

Dimmer Compatibility List:

- Leviton: IP710-DLZ, DS710
- Lutron: DVSTV-WH, MS-Z101
- Eaton: WBSD-010SLD
- LeGrand: RH4FBL3PTC
- Hubbel: LHDIRS3N

Warranty

- 5 Year Warranty
- See warranty documentation for more information.



ORDERING INFORMATION **EXAMPLE: WT-22-30-C-U-90CRI**

WT	SOLD IN 4-PACKS ONLY					
Series	Size	Wattage	CCT	Input Voltage	CRI	EM
WT	14 - 1'x4' 22 - 2'x2'	24 - 24W 30 - 30W 36 - 36W	C - 3000K/3500K/4000K	U - 100-277V	90CRI	EM - EM Backup [Sold as Individual Units Only available for 2'x2' & 2'x4']
	24 - 2'x4'	24 - 24W 36 - 36W 45 - 45W				

Accessories

- ELIS10CDF (Bodine 10W Inverter)
- TGS-15W-INT (EM Inverter 15W)
- T-BR-EM (T-Bar Bracket for EM Backup)
- FCJS0 (Lutron Vive PowPak)

DIMENSIONS

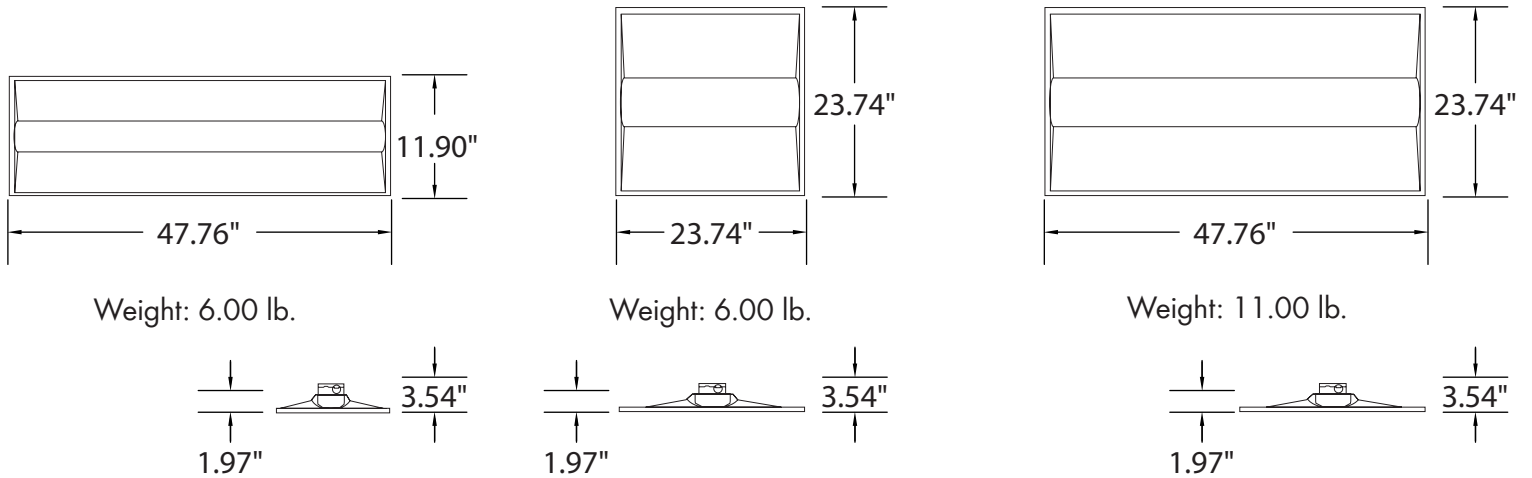

LUMEN OUTPUT

SKU	Size (LxW)	Wattage (W)	Delivered Lumens (lm)	Efficacy (lm/W)
WT-14-24-C-U-90CRI	1'x4'	24	3120	130
WT-14-30-C-U-90CRI	1'x4'	30	3900	130
WT-14-36-C-U-90CRI	1'x4'	36	4680	130
WT-22-24-C-U-90CRI	2'x2'	24	3120	130
WT-22-30-C-U-90CRI	2'x2'	30	3900	130
WT-22-36-C-U-90CRI	2'x2'	36	4680	130
WT-24-24-C-U-90CRI	2'x4'	24	3120	130
WT-24-36-C-U-90CRI	2'x4'	36	4680	130
WT-24-45-C-U-90CRI	2'x4'	45	5850	130

ACCESSORIES



Recessed Mounted
Integral Clips
[T-bar]
(Standard)



Emergency
Battery Backup
[Factory Install Only]
[For 2'x2' & 2'x4']
(Option)
[EM]



Bodine Inverter
10W
(Option)
[ELIS10CDF]



Emergency
Inverter 15W
(Option)
[TGS-15W-INT]



T-Bar Emergency
Battery Bracket
(Option)
[T-BR-EM]



Lutron Vive
PowPak
[Factory Install]
(Option)
[FCJS0]