

## IMPORTANT SAFEGUARDS

*When using electrical equipment and this lighting device basic safety precaution should be followed at all times including but not limited to the following:*

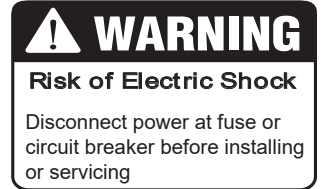

## PLEASE READ CAREFULLY AND FOLLOW ALL INSTRUCTIONS FOR YOUR OWN SAFETY

**WARNING:** AC power must be off before proceeding with assembly or installation of emergency driver.

**IMPORTANT:** For use with non-dimming LED fixtures up to 40W. For use with LED fixtures(MAX 300W) that utilize 0-10V dimming that are above 40W, but this inverter will be limited to 40W(Including driver).

**IMPORTANT:** An un-switched AC power source of 100Vac to 277Vac is required.

**CAUTION:** Make sure all electrical connections conform to the National Electrical Code and all applicable local regulations.

**CAUTION:** Do not let power supply cords touch hot surfaces.

**CAUTION:** Do not mount near gas or electric heaters.

**CAUTION:** Use with grounded, UL Listed, dry or damp or wet location rated fixtures.

**CAUTION:** The equipment is intended for ordinary locations and for permanent installation into one or more Listed emergency luminaires.

**CAUTION:** Battery is rechargeable LiFePO4 type and must be recycled or disposed of properly.

Do not use this emergency driver with accessory equipment other than recommended by manufacturer; failure to follow this may cause an unsafe condition. Servicing should only be performed by qualified service personnel. Do not use this emergency driver for other than intended use. Not suitable for high-risk task area lighting. Equipment should be mounted in locations and at heights where it will not readily be subjected to tampering by unauthorized personnel.

**IMPORTANT:** Indicator (LED light) illuminated indicates battery in charge mode when AC power is applied. It is recommended and required by applicable code to test emergency LED Driver to ensure proper function of the system; push the test switch every thirty (30) days to ensure the emergency driver is functioning by illuminating the light source. Conduct a ninety (90) minutes discharge test one (1) time per year; LED light source should be illuminated for a minimum of ninety (90) minutes .

**TESTING SYSTEM:** The emergency battery requires a charge minimum of one (1) hour before testing the circuit. A full charge requires twenty four (24 Hours) .

**SAVE THESE INSTRUCTIONS**

**Make sure that the luminaire used meets the voltage and current requirements in the Product Information List and the illumination requirements in NFPA101.**

Ensure there will be sufficient light output in the end application. Estimate the egress lighting illumination levels by doing the following:

- a. Find the efficacy of the LED load. This can be provided by the luminaire manufacture. This number will be given in lumens per watt (lm/w). It is the installer’s responsibility to validate the luminaire manufacturer’s efficacy data. This can be accomplished by direct measurement, by review of independent 3rd party test data (UL, ETL, etc.), accessing a public database of 3rd party data (such as Design Lights Consortium, www.designlights.org), or other comparable means.
- b. Lumens can be calculated by multiplying the output power of the backup inverter by the efficacy of the LED load. In many cases the actual lumen output in emergency mode will be greater than this calculation gives, however it will provide a good estimate for beginning the lighting design of the system.
- C. Using the results of this calculation and industry standard lighting design tools, calculate the anticipated illumination levels in the path of egress.

**Lumens In Emergency Mode = Lumens per Watt of Fixture \* Output Power of Chosen Product**  
**\_\_\_\_\_ (Lumens) = \_\_\_\_\_ (lm/W) \* 40(W)**

**NOTE:** This product has been designed to reliably interface with a wide selection of LED Drives. However, compatibility cannot be guaranteed with all current and future LED systems. Compatibility testing of the end-use system is suggested. Please contact the factory with any questions.

## **PRODUCTION INFORMATION**

---

- Backup Inverter
  - Universal Voltage: 100-277Vac, 50/60Hz
  - Output Wattage: 40W
- 

### General Specifications

Input Voltage	100-277Vac, 50/60Hz
Input Current	0.2A Max.
Input Power	12W Max.
Maximum Load Power	300W (When dimming to a minimum, the power needs to be less than 35W)
Standby Input Power	<0.8W (Finished charging)
Maximum standby time between Recharges	12 Month
Driver Type	Constant power
Output Power(Emergency Mode)	40W
Output Voltage Range	120-200Vdc
Response time	≤5S
Number of Output Channels	1 Channel
RFI/EMI	FCC Part 15 Class B
Output Type	LED Class 1
Battery Type	LiFePO4 16Vdc
Battery Capacity Available	6000mAh(96WH)
Battery Recharge Time	24Hours
Battery Discharge Time	90 Minutes Min.
Maximum lighting fixture weight	20Kg
Maximum mounting height	36FT (11m)
Service Life	50,000 hours

## Self-Diagnostic Test System

In the normal charging mode, the system performs a monthly self-diagnostic test every 30 days, the system switches to the emergency mode for 30S, and automatically switches back to the normal charging mode after 30S.

In the normal charging mode, the system switches to the emergency mode every 360 days (after 11 Months self-diagnostic test) and works until the end of discharge. Automatically switches back to normal charging mode after discharge.

Ambient Operating Temperature Range

10°C to 50°C (50°F to 122°F)

Input Surge Protection

2.5KV Ring Wave,L-N & L/N-PE 3KV/1.5KA

Protections

Battery Over Discharge Protection  
Output Short Circuit Protection

Approvals / Class

RoHS , UL924 Listed  
Dry, Damp and Wet Locations

## TEST SWITCH INDICATOR STATUS:

LED Indicators Status	THE BACKUP INVERTER Status/Mode
● Solid Green ON	System OK/AC OK .
● None LED OFF	System NG,battery voltage is too low, LED fixture is Short .
● Flashing Green, 1s on/1s off (cycle)	Battery not detected, check battery connection.
● Flashing Green, 0.1s on/5s off (cycle)	EM working in Emergency mode.
● Slow Flashing Green, 5s on/5s off (cycle)	Discharge time is less than 90 minutes(Self-diagnostic test), LED fixture is Open Circuit , Over Load .
● Flashing Green, 1s on/1s off ( 5 times)	Disable Self-diagnostic test system.
● Flashing Green, 1s on/1s off ( 3times)	Enable the Self-diagnostic test system.

## TEST SWITCH OPERATION:

### 1. Manual Diagnostic Mode:

Under the normal charging mode, after the battery is charged for 12 hours or fully charged, long press the test button for 3S and hold it, enter the manual test mode, release the button to exit the manual diagnostic mode.

### 2. Enable / Disable Self-Diagnostic Test System:

Under the Normal Charging Mode, press the button twice in two seconds, then press the button longer than 2S and less than 5S, then press the button twice in succession, the indicator light will be on and off for 5 times (1S interval), means disable the Self-Diagnostic Test System successfully. If you want to enable the Self-Diagnostic Test System, repeat the operation, the indicator light will be on and off for 3 times (1S interval), means "Enable".

### 3. Enter Sleep Mode:

Under EM mode, press the test button 3S, the Backup inverter will enter Sleep Mode(Storage and transportation),and activate it by connecting to AC power.

## REMOTE CONTROL OPERATION:

Under the normal charging mode, press the "ON" button of the remote control to enter the manual diagnostic test mode, and press the "OFF" button of the remote control to exit the manual diagnostic mode.

When press the "ON" Button, do remember press the "OFF" button later.

# Wiring Diagram and Dimensions

unit: Inch

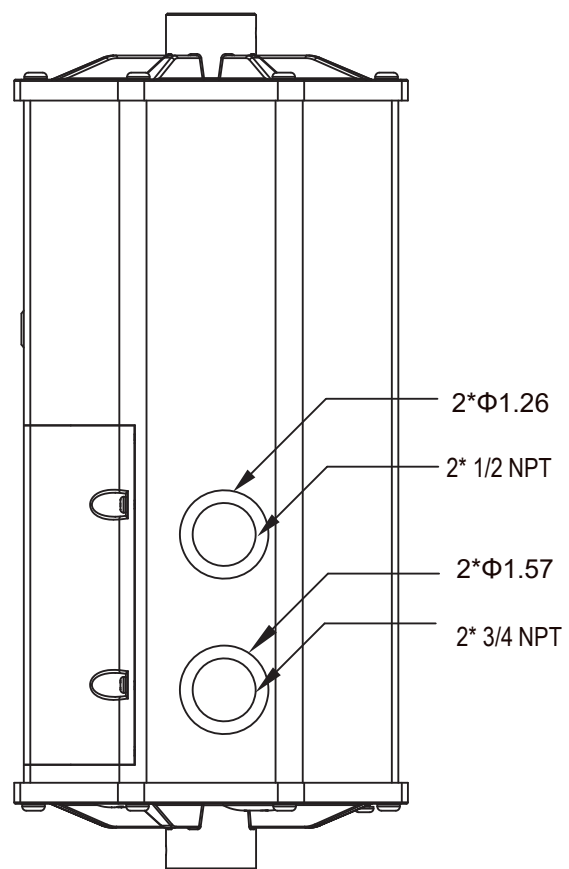
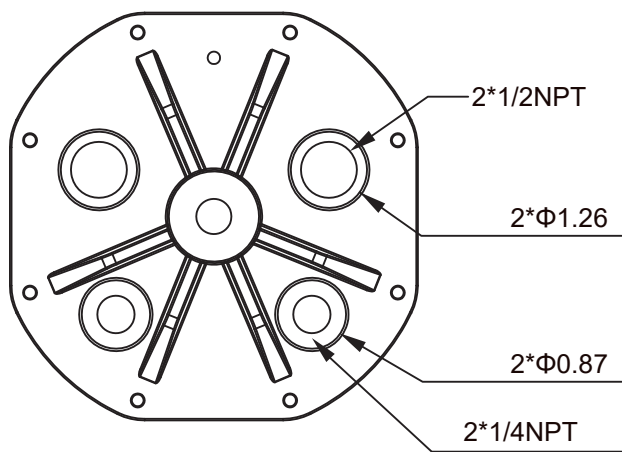
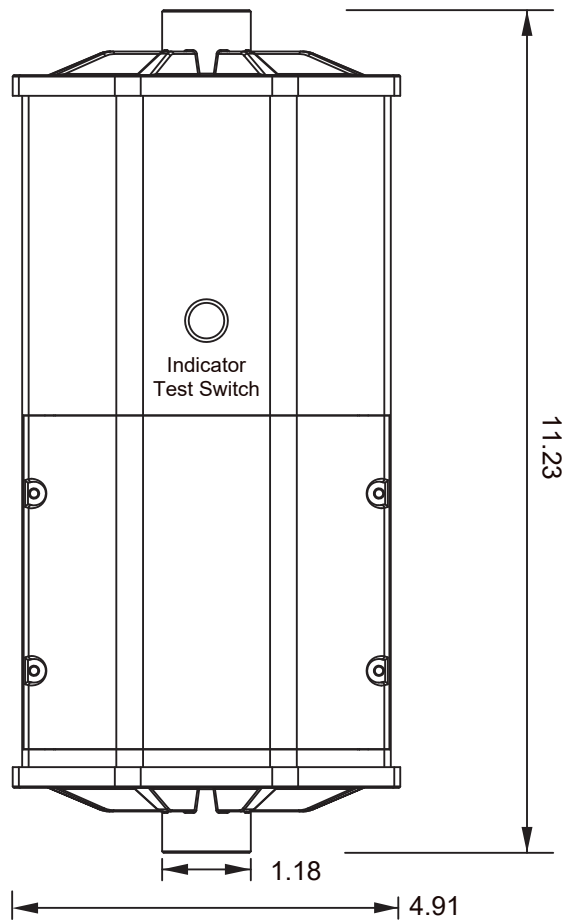
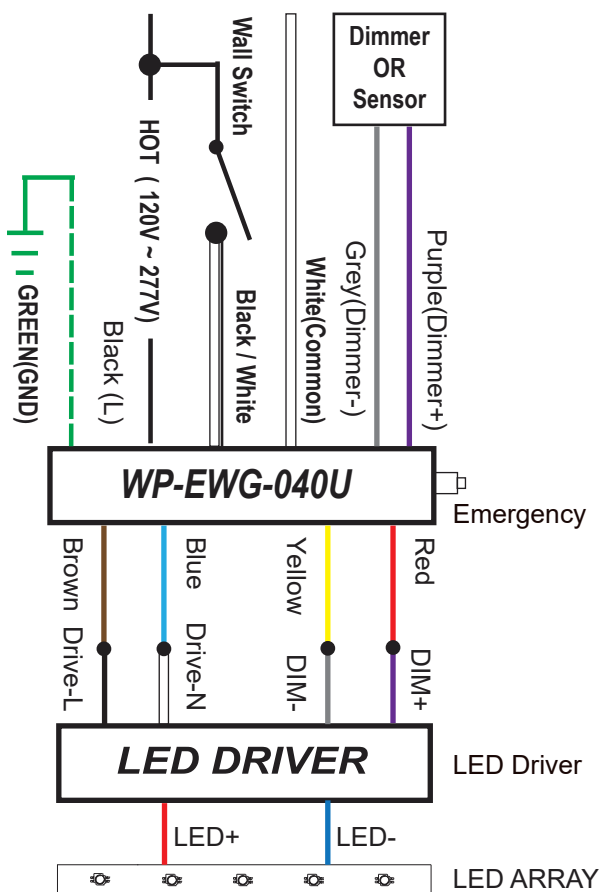

## INSTALL STEPS

### ► Step #1 Disconnect AC Power From Fixture

- > Disconnect all power sources to the lighting fixture and ensure they are locked out during installation or maintenance.
- > The AC driver must be sourced from the backup inverter.
- > Select a suitable location for the backup inverter and install such that its output leads can connect to the input leads of the AC driver.

### ► Step #2 INSTALL THE BACKUP INVERTER

- > Select a suitable location on the ceiling for hangable device.
- > Install the ring bolt (1) to the backup inverter (2) and fix it with screw.
- > Install the hook (10) to the backup inverter (9) and fix it with screw.
- > Open the cover of junction box (5).
- > Install the Bushing (7) (BN-M12-8, Suitable for wire diameter 4-8mm, STYLE, SJTW, SJOW, SVT)
- > Install the Bushing (8) (BN-M18-10, Suitable for wire diameter 6-10mm, SJTW, SJOW, STYLE, SVT)
- > Hang the backup inverter to the hangable device on the ceiling.
- > Hang the LED lighting fixture (11) to the hook of the backup inverter.
- > Install the Bx cables on AC wires (3) and dimming wires (4).
- > See Illustration 1, for typical installation and select appropriate mounting method

**NOTE:** Bushings are not installed on the backup inverter at the factory, but packed in the kits bag.

### ► Step #3 WIRING THE BACKUP INVERTER

- > Use the wiring diagram found on page 4 as reference.
- > Connect the AC power source leads (Switched and Unswitched) to the input of the backup inverter.
- > Connect the output leads of backup inverter to the AC driver.
- > Wire the AC driver with the lamp in accordance with manufactures installation instructions.
- > Make sure all connections are in accordance with the National Electrical Code, Canadian Electrical Code and any local regulations.

### ► Step #4 LOCK UP THE COVER OF JUCTION BOX & APPLY POWER

- > After installation is complete, apply AC power.
- > At this point, power should be connected to both the AC driver and the backup inverter, and the Charging Indicator Light should illuminate indicating the battery is charging.
- > A short-term discharge test may be conducted after the backup inverter has been charging for 1 hour. Charge for 24 hours before conducting a long-term discharge test.

# Illustration 1

