



THINTEK™ WAFER S **Direct Mount Recessed**

DESCRIPTION

The ThinTek™ Wafer series from TGS allows for easy installation from below the ceiling without the need for an existing can and is ideal for shallow ceiling plenum applications. The CCT switch allows for selection between 2700K, 3000K, 3500K, 4000K, and 5000K. With Title 24 certification, 90 CRI, and a variety of sizes and lumen packages, ThinTek™ Wafers provide versatility, reliable performance, and a fast, simple installation process.

APPLICATIONS

Residential, Institution, Hospitality, Retail, Offices, Schools, Basement remodels, Kitchens and Hallways.

FEATURES

Construction

Die-cast aluminum housing and PC lens.
Air-tight IC Rated.

Optical System

Glare controlling lens for comfortable light distribution.
Provides a 110° beam angle.

Warranty

5 year warranty.
See warranty documentation for more information.

Electrical

Input voltage: 120~347VAC, 60Hz
16W or 25W High Voltage Emergency Battery Backup option available.
12" Power Cable (Standard): Extension Cable option available.

Installation/ Mounting

Recessed Mounting with adjustable spring loaded retention tabs for secure fixture.

Controls/Dimming

0-10V Dimming (Dims to 10%)
CCT Switchable between 2700K, 3000K, 3500K, 4000K, 5000K.



ThinTek™ Wafer S

- 3", 6W (370 lm)
- 3", 8W (500 lm)
- 4", 10W (650 lm)
- 4", 12W (850 lm)
- 6", 12W (900 lm)
- 6", 15W (1100 lm)
- 8", 18W (1500 lm)

Projected L70: 50,000+ hours
Warranty: 5 Years
0-10V Dimming (10%)



TITLE 24
Compliant



90+ CRI



Wet
Location
Rated



CCT
Switchable



Air Tight

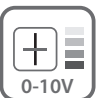

0-10V
Dimming
Dims to 10%

Ordering Information

EXAMPLE: TWSF-0306-C-U

Series	Size/Wattage	CCT Switchable	Input Voltage/Control
TWSF - ThinTek Wafer Square Flat	0306 - 3"/6W 0308 - 3"/8W 0410 - 4"/10W 0412 - 4"/12W 0612 - 6"/12W 0615 - 6"/15W 0818 - 8"/18W	C - 2700K/3000K/3500K/4000K/5000K	U - 120~347VAC/ 0-10VDimming

Accessories

- TW-EC (12" Extension Cable)
- 90016-H (16W High Voltage Emergency Battery Backup)
- 90025-H (25W High Voltage Emergency Battery Backup)

Specifications and Dimensions subject to change without notice.

*MOQ and longer lead times may apply, please contact customer service for more information.

Accessories options are purchased separately.

Performance Information

Input Voltage	120~347VAC
Input Frequency	60Hz
Wattage	See Performance Table
Delivered Lumens	See Performance Table
Efficacy	See Performance Table
CRI	>90
Available CCT	2700K, 3000K, 3500K, 4000K, 5000K
Projected L70	50,000+ hours
Power Factor	>0.9
THD	<20%
Dimming	0-10V Dimming (Dims To 10%)
Operating Temp.	32°~104°F

Photometric Data

6" 15W

* IESNA LM-63 IES Available

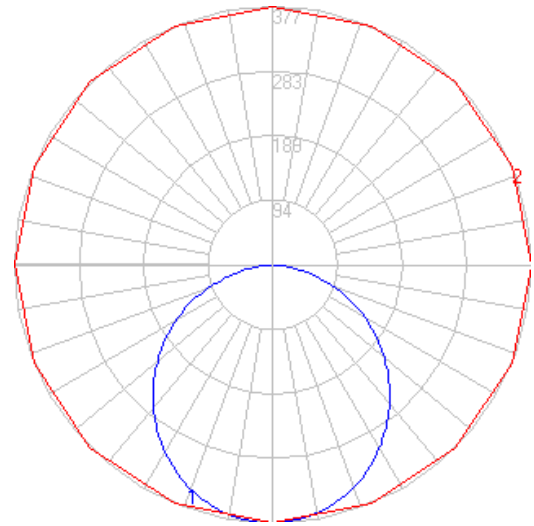

Performance Table

SKU	Size (in)	Wattage (W)	5000K	
			Delivered Lumens (lm)	Efficacy (lm/W)
TWSF-0306-C-U	3	6	370	62
TWSF-0308-C-U	3	8	500	63
TWSF-0410-C-U	4	10	650	65
TWSF-0412-C-U	4	12	850	71
TWSF-0612-C-U	6	12	900	75
TWSF-0615-C-U	6	15	1100	73
TWSF-0818-C-U	8	18	1500	83

Product Dimensions

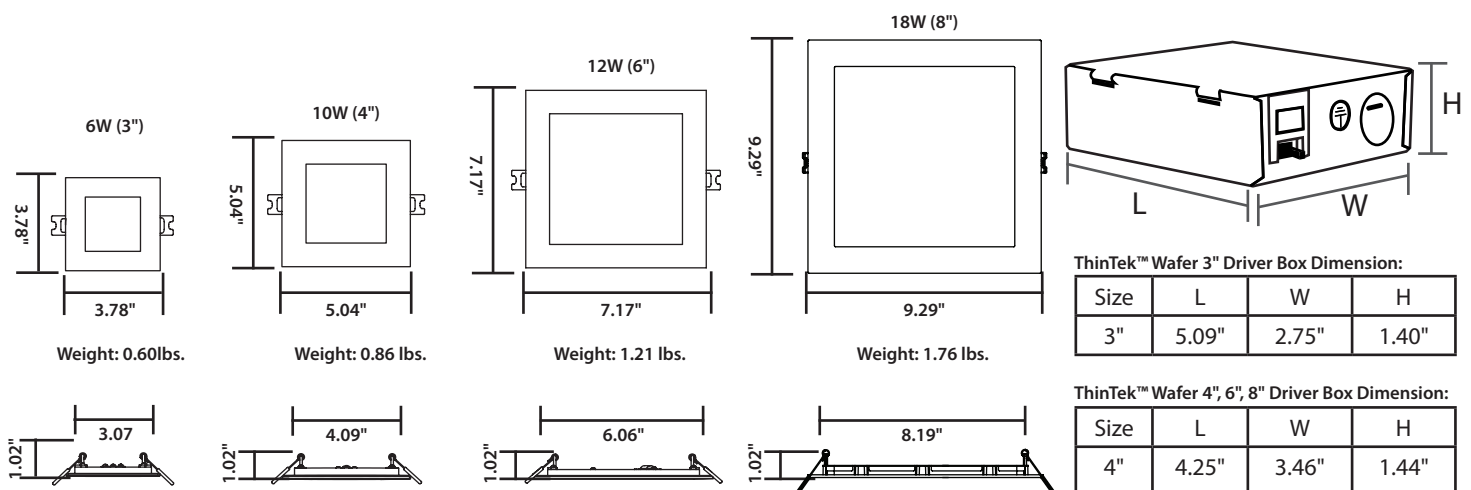

Installation Kits and Accessories



**12" Extension Cable
(Option)
[TW-EC]**



**High Voltage
Emergency Backup
16W or 25W
(Option)
[90016-H,
90025-H]**